



## Settings



### Power Control

See pages 2-7 on Power Control, Work Modes, Smart Loads, Battery Time Base Control



### Battery

See pages 8-10 on Battery



### General

See page 11 on General



### Grid

See pages 12-13 on Grid



### Communication

Enter WIFI SSID and Password



## Power Control

### Work Mode

- \*Self Consumption
- \*Grid feed in priority
- \*Off Grid

See full discussion of Work Modes on page 4, and examples of how they are used along with Time Based Control on page 6-7. If the grid fails, it switches to Off-grid mode automatically.

### Support Normal Load

\*On/Off: Should the system export to the non-backed up panel based on CTs, or just to the backed up panel load. "Normal load" is the term used for loads not fed by backup power. See diagram below. If the grid fails, the internal transfer relay opens, and power is only fed to the backed up loads, regardless of this setting.

### Zero Export

\*On/Off: Can the system export to the grid or not. If turned off, the system will only support local loads (just the backed up panel, or the entire location if CT's are enabled via "support normal load" It may be necessary to adjust "Maximum Consumption from Grid" (next page) to prevent inadvertent overshoot of zero when large loads turn off.

### Smart Load

Smart Loads 1 through 3 — see page 3 on Smart Load controls  
This is also where Generator settings are done

### Power Control

Use either CT sensors or a Smart Meter (used for larger or three phase systems) to measure power to/from grid

### Sensor Location

CT sensors can be installed on grid or load side of inverter-grid interconnection spot. See diagram below.

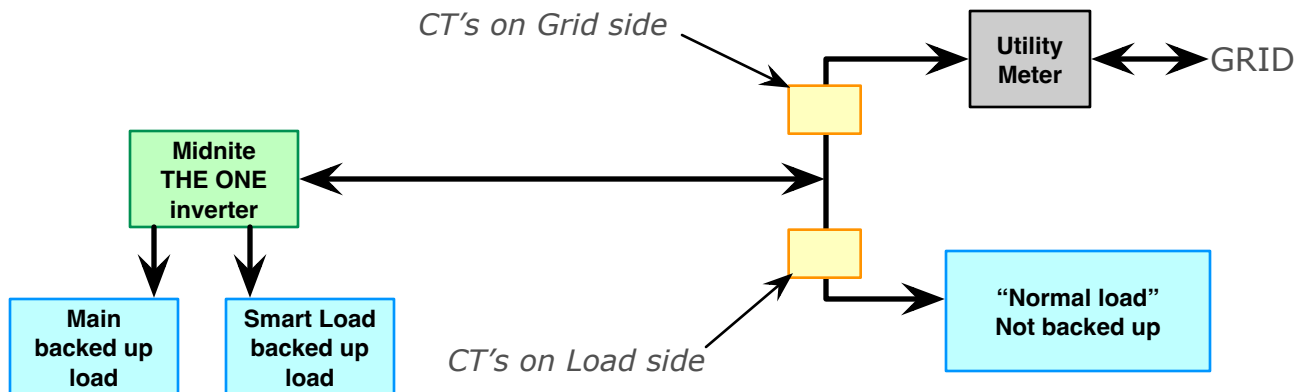



## Power Control

### Energy Flow Direction

Which direction are CT's installed. Arrows (flow direction) should be facing inverter. But if both are installed backwards, this can be changed in software. Only if BOTH of them are backwards.

### Power Derating Control Method

PCS-ESS setting. Control power based on minimum phase, total of both phases, or independent phase power. Generally don't change this from default except under supervision of an engineer.

### Maximum Feed in Grid Power

Maximum power sent to grid (exported from inverter if "support normal load" is off. Exported through CT's to grid if "support normal load" is on). Range: 0W to 11,400W. If Zero Export is on, then 0 is used. If grid interconnection agreement has a limit (example: utility doesn't allow exporting over 5kW), or if export power must be limited because of NEC 705.12(B) "120% rule for backfed circuit breakers", this may be set lower than the full inverter power.

### Maximum Consumption from Grid

30 to 500 watts. This is a small positive import value from the grid to maintain to prevent accidental exporting to the grid in Zero Export mode. If a large load turns off, especially large inductive loads, it can take a moment for the inverter to respond and reduce export power, and the system can export power to the grid for a few seconds. Keeping a small amount of import from the grid rather than actually going to zero during Zero Export can keep this from happening. But it will lead to higher energy consumption from the grid as well. With older mechanical meters this was not a concern, but with new smart meters it can be, especially if operating without any interconnection agreement with the utility.

### Battery Schedule Time Base Control

Scheduling when to charge and discharge batteries — see page 5 on Battery Time Base Control, and the Examples on pages xxxxxxxx



## Smart loads

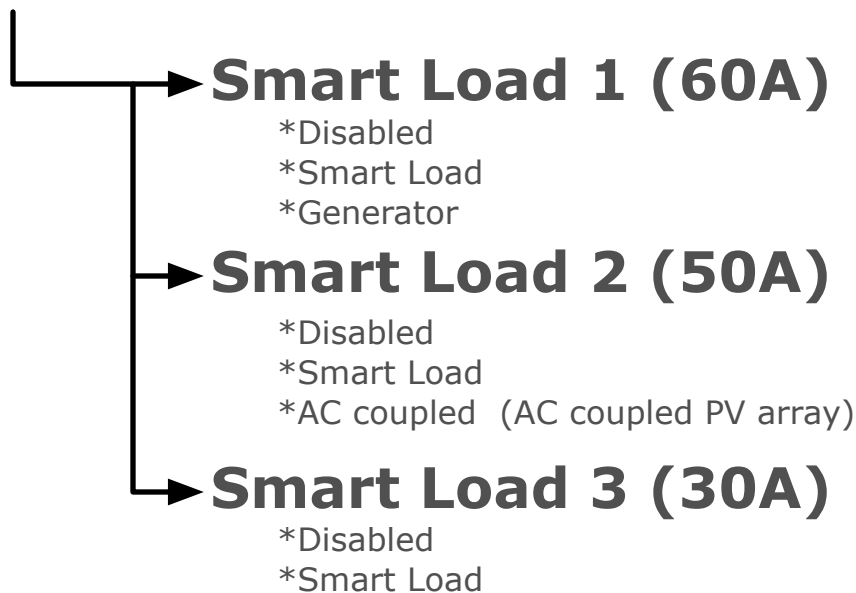

## Description of Smart Load Control Options

### Smart Load

Turns output off below a certain low SOC. Turns back on at another higher SOC. *Example: 50/80. Turns load off when batteries drop to 50% SOC. Turns load back on when they recharge to 80% SOC.*

### Generator

#### Option for Smart Load 1: Settings

- \*Maximum input power from Generator: Power from 0 to 14,400 watts
- \*Maximum charge power from Generator: Power from 0 to 10,000 watts
- \*Generator start and stop SOC: Set SOC for generator to start at and SOC for generator to shut off at. NO RAMPING  
*Example: 40/80. Starts generator when batteries drop to 40%. Shuts generator off when they recharge to 80%.*
- \*Generator maximum run time and standby time. Number of minutes to run the generator after stopping charging, to let the generator cool down. Maximum number of minutes that generator can run at a time (even if charging is not complete)
- \*Dry Force Control: set generator control contacts to auto, or to manual on.
- \*Run Cycle: set exercise cycle every week or month or disable.

### AC coupled

#### Option for Smart Load 2: Settings

- \*AC coupling start and stop by SOC: Turns AC coupled PV array off at high SOC, turns AC coupled PV array back on at lower SOC  
*Example: 95/100. Turns array off at 100%, turns array back on at 95%*
- \*Off Network output maximum frequency — If there is AC coupled input when the grid is down (or if in Off-grid mode) it will raise the frequency to throttle the PV array with a UL1741SA or SB compliant inverter. This sets the maximum frequency it will rise to.

**NOTE: limited export does not work with an AC coupled PV array. It will sell to the grid when PV production exceeds local load**



There are three different work modes available: Self Consumption, Grid Feed Priority (Sell to Grid) and Off Grid. The modes affect the priority of where incoming solar power is used. In any case, incoming solar power is first used for local loads (backed up loads, and other local loads if “support normal loads” is on). What the system does if there is more PV power than needed for local loads varies depending on the work mode:

The time base control overrides the modes, and affects battery charging or discharging at certain times. In addition, charging from the grid can be turned on or off — if it is turned off, the time based charging affects charging of the batteries from solar only.

### **Self Consumption**

If there is excess PV input above what the loads need, it is used to charge the batteries. If the batteries are full, the excess power is exported to the grid, up to the amount of grid export allowed (zero if zero sell is on). If incoming PV is less than the loads, power is drawn from the batteries to send to the loads, until the batteries are discharged to the limit set in Discharge SOC (on grid), when it starts passing grid power through to the loads.

### **Grid Feed in Priority (Sell to Grid)**

If there is excess PV input above what the loads need, it is exported to the grid. This means that the battery will not charge or discharge unless Time Charging is turned on and configured properly. The point of this mode is to sell as much power as possible to the grid and only use the battery for small windows of time or for when the grid power is lost.

**Allow Charging from Grid** determines if the system will use grid power to charge the battery or not. If set to "Do Not Allow" then the battery will only ever charge with PV power. In certain areas, this may be required by the utility or tax regulations. If this is the case, the PV array must be large enough to charge the battery after taking care of local loads if in Self Consumption Mode and a time base control window for battery charging must be set during the daytime if in Grid Feed in Priority Mode. Otherwise the batteries may never get charged.

### **Off Grid**

This mode should only be used for people that are installing the inverter completely without grid power. For this mode, no cables should be landed in the "AC Grid" terminals of the inverter. When operating in this mode, the inverter will supply power to the backup loads from the PV and the battery depending on what is readily available, as long as the battery is above the minimum SOC, or minimum voltage (depending on whether it is an open loop or closed loop battery). The AC grid terminals however, can be used for a second generator input (or larger amperage generator input).

If grid power is lost, the inverter automatically switches to off-grid mode.

The next page gives some examples of ways you might typically use these modes



## Time Base Control schedule

- **Storage Timebase 1**
- **Storage Timebase 2**
- **Storage Timebase 3**

### For each Timebase Period

- **Charge Start and End Times**
- **Discharge Start and End Times**  
Times are in 24 hour format. Time periods may not overlap from charge to discharge and may not overlap other time periods. Setting to 0:00 for Start and End disables a time period.
- **Repeat**  
Repeat every day, or just once (just once can be useful if you want to start recharging the battery and shut off once it's done, but not repeat every day — for example if you get a 3 hour notice of a scheduled blackout)
- **Charging Power**  
Charging Power from 0 to 10,000 watts. If Charge by Grid is disabled, then the batteries will only charge from available solar after load is met.
- **Battery Charge Stops at SOC**  
Battery SOC at which charging stops
- **Discharging Power**  
Discharging Power from 0 to 10,000 watts.
- **Discharge stops at Battery SOC**  
Battery SOC at which charging stops

This gives options for a total of 3 charge periods with different times and charging rates and stopping SOC, and 3 discharge periods with different times, discharge rates, and stopping SOC

***Time Based Control will supersede the Work Mode setting during the time periods programmed!***



## Settings: Power Control: Examples 1

These are some examples of how the various work modes along with time based control and charge from grid on/off can be used to address interacting with various grid prices.

*For these, understanding the value of energy stored in the battery is important. Based on the cost of the battery of \$4000, and the rated cycle life of 8000 cycles to 80% DOD on a 16kWh rated battery, this translates to storing 1024 MWH stored over its lifetime, so it costs about 4 cents for every kWh stored and returned. Therefore, it makes sense to switch to using energy from the battery for the home if the grid electricity costs greater than 4 cents higher than the electricity that was used to charge the battery (either what the grid was charging when the battery was charged, or what the value of the PV electricity would have been when sold to the grid instead of being used to charge the battery).*

### **#1) Net metering and backup power, with grid charging allowed:**

Set to Grid Feed In Priority, with Time Base Control set to allow charging of the battery to 100% from 0:00 to 24:00 (all times) and Charge by Grid (pg 10) on. This will export all excess solar power to the grid after meeting local loads, and will recharge the battery from PV or grid if it isn't full. The only time the battery is discharged is if the grid goes down and the system switches to off-grid mode. Recharge after a power outage occurs as soon as the grid comes back. We could select 95% instead of 100% to prevent undue wear on lithium batteries by being at 100% all the time, however the BMS on Midnite batteries will protect them even if 100% is chosen.

In this scenario, all grid/PV electricity is the same value, so it doesn't make economic sense to discharge the batteries unless the grid is down.

### **#2) Net metering and backup power, with no grid charging allowed:**

Set to Grid Feed In Priority, with Time Base Control set to allow charging of the battery to 100% from 0:00 to 24:00 (all times) and Charge by Grid off. This will export all excess solar power to the grid after meeting local loads. If the battery is not full, then it will first charge the battery before exporting excess solar power. The only time the battery is discharged is if the grid goes down and the system switches to off-grid mode. Recharge after a power outage occurs on the next sunny day where there is excess solar over the loads, rather than that night, so we do run the risk of having drained batteries if the grid is going on and off during a period of low solar input (snowstorm).

**#3) Net metering, but with a high peak rate in the evening.**

*12 cents for most of the day, 32 cents from 16:00 to 20:00*

Set to Self Consumption, with Time Base Control set to allow charging of the battery to 90% from 0:00 to 15:00 and 20:00 to 24:00, and to 100% between 15:00 and 16:00. It will top off the batteries starting at 15:00 just before peak rates start (with excess solar if available, with grid otherwise). Between 16:00 and 20:00 it will revert to self consumption and power load from batteries (or solar if still available). From 16:00 to 20:00 it will support the local load from the battery if there is insufficient solar power, rather than drawing from the grid. At 20:00 it will recharge the battery from the grid, if Charge by Grid is on, or will wait till morning and recharge the battery with solar power (excess over that needed to meet local loads). Once the batteries are full, it will export excess solar over what is needed by the local loads. To get the best advantage of this, allow it to “support normal loads” to offset the non-backed up (“normal”) loads during peak times.

In this scenario, we are charging the battery at 12 cents, and discharging it at 32 cents. This is a greater than 4 cent spread, so makes sense economically.

**#4) No net metering, selling allowed.**

*Buy at 12 cents, sell at 3 cents.*

Set to Self Consumption with Charge by Grid off. This will operate the loads from the batteries + solar, and will only sell to the grid if the batteries are full and there is excess solar over the load. It will only draw from the grid if the batteries are discharged to the Discharge SOC (on grid). This minimizes the selling of PV, while still allowing it. If solar is insufficient to cover the loads, the batteries may sit mostly discharged for large portions of time. It may be necessary to do a Force Charging every once in a while in low solar periods to bring the battery SOC up. To get the best advantage of this, allow it to “support normal loads” to offset the non-backed up (“normal”) loads.

If the differential between buy and sell rates is less than 4 cents (the cost of using batteries), then it may make more sense economically to set this up more like example 1 or 2 rather than discharging the batteries at night.

**#5) No net metering, no export allowed**

**(either without an interconnection agreement, or no selling is allowed by the interconnection agreement)**

Set to Self Consumption with Charge by Grid off, and Zero Export on and Maximum Feed to Grid Power set to zero. This will operate the loads from the batteries + solar, and once the batteries are full, it will curtail the solar production to prevent selling to the grid. It will only draw from the grid if the batteries are discharged to the Discharge SOC (on grid). If solar is insufficient to cover the loads, the batteries may sit mostly discharged for large portions of time. It may be necessary to do a Force Charging every once in a while in low solar periods to bring the battery SOC up. It may be necessary to adjust the Maximum Consumption from Grid depending on what loads are present to prevent overshoot and inadvertent selling to the grid during load changes. To get the best advantage of this, allow it to “support normal loads” to offset the non-backed up (“normal”) loads as well.





Some more complicated examples

**#6) Net metering with time of use rate: Buying and selling from batteries is allowed.**

*Time of use rate is 8 cents between 21:00 and 13:00, 15 cents from 13:00 to 18:00, and 30 cents in evening from 18:00 to 21:00*

Set to self consumption, with Time Base Control for charging to 90% from 0:00 to 12:00 and 21:00 to 24:00. Time Base Control for charging to 100% from 12:00 to 13:00. Time Base Control for discharging to 25% from 18:00 to 21:00 at 10kW (or 7.6kW if using a back-fed breaker on a 200A panel). This will dump the batteries to the grid during the peak rates, selling as much as is left over after meeting the local loads, until the batteries drop to 25%. During off peak rates, it will recharge the batteries to 90%, then charge them to 100% an hour before mid-peak rates start. During midpeak rates, it will sell excess solar to the grid, or power loads from the batteries if solar is insufficient to cover loads. To get the best advantage of this for the midpeak loads, allow it to “support normal loads” in order to offset the non-backed up (“normal”) loads.

In this scenario, we are charging then battery at 8 cents, then using it to offset loads at 15 cents, then dumping the rest of it at 30 cents, before recharging at 8 cents again. This greater than a 4 cent spread so makes sense economically.

**#7) Different time of use rate for both buying and selling. Selling from batteries is allowed.**

*Time of use rate for selling is 5 cents for most of the day, rising to 75 cents from 19:00 to 21:00*

*Time of use rate for buying is 12 cents from 22:00 to 12:00, 28 cents from 12:00 to 17:00, and 40 cents from 17:00 to 22:00. (This is similar to many rates in California in late summer months).*

Set to Self Consumption, with Time Base Control for charging to 90% from 0:00 to 11:00 and 22:00 to 24:00, and to 100% from 11:00 to 12:00. Time Base Control for discharging from 19:00 to 21:00 at 10,000 watts. Grid charge is disabled. This will dump the batteries from 19:00 to 21:00 during the peak selling rates, then will wait to recharge the batteries till the sun comes up in the morning. Once it is exceeding the local loads, it will recharge the batteries, then an hour before mid-peak rates start, it tops off the batteries. Once mid-peak rates start it uses a combination of solar and batteries to meet the load, only selling extra above this. This relies on the batteries + solar combination being large enough to have enough capacity to meet the load from 12:00 to 19:00, plus be able to dump at full power for two hours starting at 19:00. If they are not large enough to do both, the end of the Time Base Charging to 100% could be delayed, as it's better to sell power put into the batteries at 75 cents during the peak export period, than to use it up avoiding importing from only 28 or 48 cents, earlier. To get the best advantage of this, allow it to “support normal loads” in order to offset the non backed up (“normal”) loads.

In this scenario, we are charging then battery at 2 cents with solar that would otherwise be sold to the grid for cheap, hopefully use more 5 cent power to top the batteries off (or at worst some 12 cent power) then using the battery storage to offset loads first at 28 cents, then 40 cents, then finally dumping the rest of the batteries at 75 cents, before waiting till the next morning to recharge at 2 cents again. This is greater than a 4 cent spread so makes sense economically. Even charging at 12 cents and discharging at 28 to 75 cents would make sense economically, but it's even better to charge at 5 cents (what we'd otherwise make selling PV for most of the day).



### #8) High peak demand charge from utility

*Demand charge of \$15/kW, energy sell, buy, xxxxxxxxx*

Limit import from grid using Maximum Input Power From Grid setting at 3kW. Set to self consumption work mode. Xxxxxxxxxxxx. Time Base Charge set to xxxx watts from xxxxx time to 75%.

System will only draw small amounts of power from the grid, up to 3kW. If load exceeds that, the solar and/or batteries supply the rest. If the batteries get below 75%, they are recharged from the grid, but only slowly (when the load is below 3kW). Otherwise, they are charged by solar when there is excess. Or .....

Exact values may have to be adjusted based on size of battery bank, kWh per day load, and amount of solar production.

***Note that the Time Base Control settings are not programmable to be different for different months, and most rate schedules using time of use rates will vary from summer to winter, and some from month to month. Thus it may be necessary to change the programming as needed to match the particular utility rates for each season or month.***



## Battery

Options for closed loop batteries (communications between batteries and inverter)

Options for open loop batteries (no comms)

### Battery Brand Selection

- \*Unavailable
  - \*Lead Acid Battery
  - \*PYLON
  - \*UZ
  - \*MidNite Battery (lithium valley, eve)
  - \*Lithium Battery (No BMS comms)
- These are either open loop (no communications between inverter and battery) for Unavailable, Lead Acid and Lithium Battery, or closed loop (communications between inverter and battery) for PYLON, UZ, and MidNite battery

### Battery Capacity (AH)

Set battery AH capacity from 0 to 65,535 AH

### Battery Charge Efficiency

Set Battery efficiency from 0 to 100%, for open loop batteries only

### Battery Rate Temperature

This is only for midnite batteries. Don't touch this.

### Lead-Acid Battery Impedance

In miliohms, from 0 to 500, For lead acid batteries only. Better quality batteries will include this information on the spec sheets.

### Floating Charge Voltage

Set float charging voltage, for open loop batteries only. 40V to 64V

### Bulk Charging Voltage

Set absorb charging voltage, for open loop batteries only. 48V to 65V

### Stop Discharge Voltage

Set low voltage disconnect, for open loop batteries only. 40V to 64V

### EQ Voltage

Set equalization voltage, for flooded lead acid batteries only. 48V to 65V

### EQ Time

Set equalization time in minutes, for flooded lead acid batteries only. 5 to 900 minutes (5 minutes to 15 hours)

### Maximum allowed time to try to EQ

Max minutes to try EQ. For flooded lead acid batteries only.



## Battery



### Days between automatic EQ charges

Days between EQ charges. For flooded lead acid batteries only.



### Force EQ charge now

Start EQ charge. For flooded lead acid batteries only.



### Absorb Time

Absorb time, in minutes, for open loop batteries only



### Communication Address

For closed loop batteries only

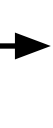

### Capacity Type

Show battery capacity in SOC or voltage. Open loop batteries can be set for SOC or Voltage, but accuracy of SOC is not good. Close loop will be SOC.



### Discharge and charge to %

Upper and lower SOC limits for battery usage, for all purposes.

Generally set to 100% for top. Lead acid batteries should always be set to 100%. Some lithium batteries may not like 100% all the time, but passively balanced batteries may also require getting to 100% to activating balancing. The Midnite battery BMS in closed loop will automatically throttle charging at the top 10% to protect the batteries and do not need to be set at less than 100%.

The lower limit is equivalent to the low voltage disconnect setting. At this point the inverter shuts off (however there will still be a draw on the battery from tare losses of the inverter brain and control system, which can further discharge the battery if it is not recharged).



## Battery

### Start and stop recovery charging when reaching discharge end SOC on grid.

Between these two SOC values, the maximum charge rate is decreased to the number in Maximum Grid Recovery Charge Power to avoid charging a deeply discharged battery at full rate. Above the upper SOC setting, charging resumes at full power.

### Discharge SOC (on-grid)

This is the minimum SOC that batteries will be discharged to when on grid (such as when doing self consumption) — think of this as the reserve amount left for backup power if the grid fails.

This can be adjusted by an end-user login to allow quickly setting the system to either prioritize operating in self consumption mode (lower discharge SOC to allow using more battery capacity daily/overnight, but not leaving much for a possible grid outage at nighttime), or to prioritize operation for backup power if a possible or scheduled grid outage is coming up (high discharge SOC setting leaving a lot of capacity for backup power needs).

### Maximum charge power

Maximum charge power of batteries (combined from all sources: solar/generator/grid). 0 to 10,000 watts.

### Maximum discharge power

Maximum discharge power of batteries to inverter, 0 to 10,000 watts.

### Maximum grid recovery charge power

Maximum charging power during recovery charging of a deeply discharged battery (Recovery charging defined as between the two set points in Stop and Start Recovery Charging).



## Battery: Grid charge section

### Charge by grid

Enable charging by grid. This can be turned off if it is undesirable to use grid electricity to charge the batteries, or if the utility does not permit charging batteries with their electricity. Tax credits for batteries can also be affected if less than xxxx% of charging is not done with solar energy.

If operating as an off grid system with no grid present, the Grid AC input of the inverter can be used a 100A generator input, or second generator input, if this is enabled.

### Stop Charging by Battery Capacity

Max SOC that the grid will charge the battery to. This is the value that "Force Charging" below will take the battery to.

### Maximum Allowed Charging Power

0 to 10,000 watts. Applies to max charge rate of batteries from just grid. Time Based Control max charge rate can be set to a lower value.

### Min. Initiation/startup battery capacity when off grid

This is the reset for a low voltage or low SOC shutdown. After a low battery shutdown event (controlled by the Discharge and Charge to %) it will wait till the Min. Initiation SOC before turning AC output back on. This is to prevent rapidly turning the load on and off if there is a small amount of solar charging present, but not enough to hold the load.

If the inverter is on grid, it will start recovery charging instead of??

Currently, in firmware version 5, this is not completely functional, so should be set lower than the Discharge to % setting, to deactivate it.

### Force Charging

Grid or generator will charge battery regardless of other settings (such as grid charging not allowed, Time Based Control not in a charging schedule). If there is sufficient PV it will use it first, before using Grid or Generator. This is accessible to the end-user login, and can be used, along with adjusting the Discharge SOC On Grid, to prepare for a pending grid outage.



## General: Grid charge section

### Enable Low Voltage Ridethrough

Will disconnect from the grid faster during brownouts if it is off. May be required to be on by some utilities for interconnection

### Enable Anti-Islanding

Turn on for any grid-tie systems. Only turn off for special microgrid use under engineering supervision.

### PV Insulation Resistance Protection Point

10-2000kohm. If insulation test is lower than this, ground fault will be shown and inverter will shut down.

### PV Leakage current protection point

1 to 1250 mA. If leakage current is greater than this, ground fault will be shown and inverter will shut down. Default setting is very sensitive, and poor quality MC4 connectors in wet conditions can cause tripping.

### Derating Setting

0 to 110%. PCS ESS setting, leave at default

### Grid Voltage Type

- \*Single Phase
- \*UL Split Phase
- \*UL 2/3 Phase (two phases of a three phase 120/208v system)

### Buzzer

On/off. On will cause buttons to beep whenever pushed.

### DRM Function

On/off. Grid demand response. This implements grid control such as frequency watt/ etc. may be required for some grid interconnections.

### Parallel Mode

On/off. CT's and BMS are master. No dip switches except for start and end

### Parallel System Battery Connect Type

- \*parallel
- \*independent

Batteries auto assign in and out ports. Out only going to the other batteries is the master. Can goes to inverter from that. 2seconds display comes on, 4 seconds to turn off. Don't touch power switches on any other batteries. Only bar display on master battery. Slaves have blinking green light.

*Can paralleled inverters have separate battery banks? How does that work?*



## Grid

### Grid Standard Code

IEEE1547 is standard for all US inverters. Some utilities or island grids may be different or have specific settings to adjust.

### Maximum input power from Grid

Maximum input power from the grid — this is maximum power including pass through to loads + battery charging. 0 to 24,000 watts. If the breaker connecting the inverter to the grid is less than 100A continuous rating (125A standard AC breaker) then this should be set to less than 24,0000 watts as appropriate.

If connected to a weak grid or one with high demand charges, this can be used to limit peak grid power used and have solar/batteries meet peak demand instead.

### Startup Time and Power Ramp Rates

These control how fast the inverter starts up, and how fast it changes power levels ??

### First Boot

Always change this. 300 sec is 5 minute wait. Change to 10 seconds or 20 seconds. Ramp 20% per second.

### Reconnect and boot

### Grid first voltage

Don't touch these.

### Grid first frequency

### Grid Reconnection Voltage

Upper and Lower voltages at which the inverter will connect to the grid after disconnecting from the grid.

### Grid Reconnection Frequency

Upper and Lower frequencies at which the inverter will connect to the grid after disconnecting from the grid.

### Reactive Power Control

Reactive Power Control Time

\*Pure merit

Cos phi Power Factor

\*Cos phi

\*Constant

\*Cos phi (P)

These are PCS ESS settings and should normally not be changed from the defaults

\*Q (U)

\*Q (P)





## Grid

### Grid protection: Frequency and Voltage, Level 2 and 1

This controls how fast the inverter disconnects from the grid for various problems with grid voltage or frequency. There are two levels — if the grid is far out of normal, it will disconnect quickly. If the grid is just a little bit away from normal, it will try to ride through the disturbance to help keep supporting the grid. Standard values for UL1741SB (IEEE 1547 are given). Your grid may have special values. These should not be changed except with approval from the utility company.

### Under and Over frequency

**Normal Frequency: 60.0 Hz**

- \*Under 58.5 Hz, disconnect after 300,000 ms (5 min)
- \*Under 56.5 Hz, disconnect after 160 ms (1 cycle of 60Hz AC)
- \*Over 61.2 Hz, disconnect after 300,000 ms (5 min)
- \*Over 62 Hz, disconnect after 160 ms (1 cycle of 60Hz AC)

A slight under frequency usually means that the grid is overloaded and needs more power. A slight over frequency means that the grid has too much power and needs less. The US mainland grid does not vary in frequency much at all due to having so many interconnected large generators setting the frequency. Smaller island grids may vary in frequency more as loads change.

### Under and Over voltage

**Normal Voltage: 120 volts phase to neutral**

- \*Between 105.6 and 132 volts — acceptable for normal operation.
- \*Under 105.6 volts — disconnect after for 21,000 ms (21 sec).
- \*Under to 60 volts — disconnect after for 2000 ms (2 sec).
- \*Over 132 volts — disconnect after 13,000 ms (13 sec).
- \*Over 144 volts — disconnect after 160ms (1 cycle of 60Hz AC).

A moderate under voltage usually means that the grid is overloaded and needs more power. A more major under voltage usually means something has failed, and the inverter needs to disconnect for safety of line workers.