

14-MNBCB2000-1 (TWO PER UNIT)

REVISION HISTORY			
REV.	DESCRIPTION OF CHANGE	DATE	SIGN

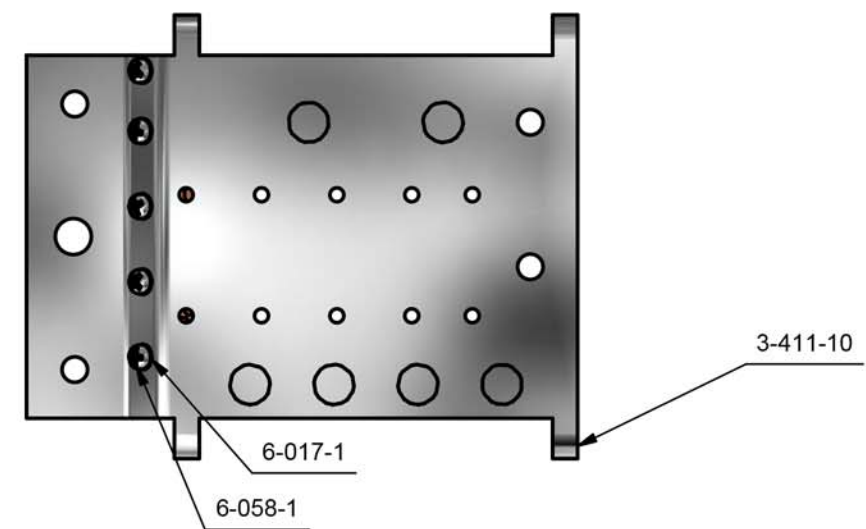
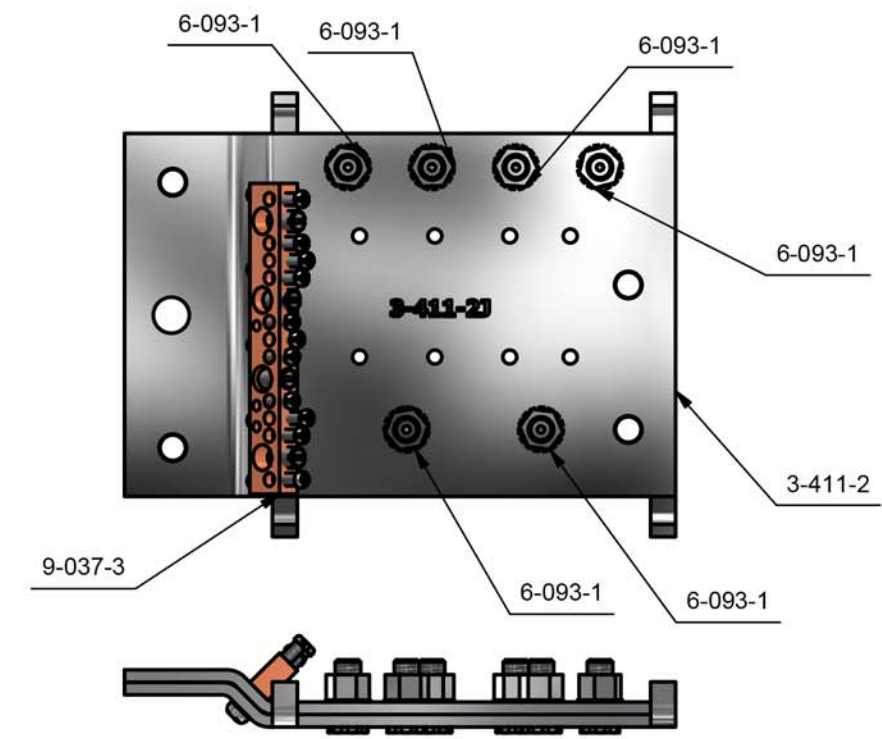
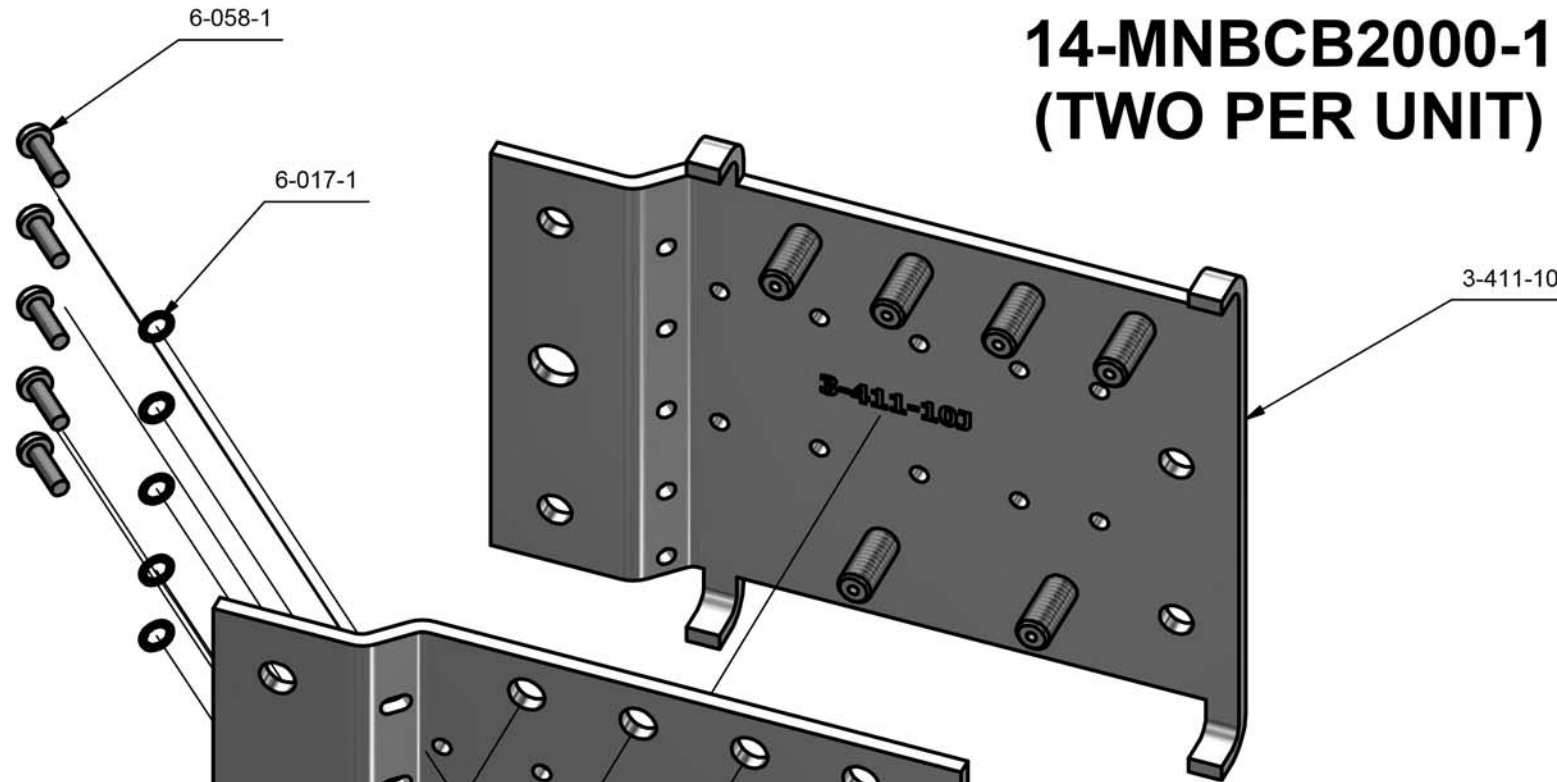

PARTS LIST		
QTY	PART NUMBER	DESCRIPTION
1	3-411-10	MNSMA BATTERY BUSBAR
1	3-411-2	MNSMA 2000 AMP BATTERY BUSBAR
5	6-017-1	INT. STAR WASHER NO.10 SS
5	6-058-1	SCREW 10-32 X 5-8 PHP SS
6	6-093-1	3/8 KEPS NUT SS
1	9-037-3	BUSBAR, 1/0 15 POSITION

ALL TOLERANCES, UNLESS OTHERWISE STATED:
 x.xxx = +/- 0.005"
 x.xx = +/- 0.01"
 x.x = +/- 0.05"
ALL ANGLES = +/- 1° UNLESS OTHERWISE STATED

MATERIAL:	STANDARDS:
FINISH:	
PROCESS:	

DRAWN Bob Q	8/22/2023
CHECKED	
QA	
MFG	
APPROVED	

MIDNITE SOLAR, INC 

TITLE: **MNBCB 2000-200 BATTERY COMBINER FINAL ASSY**

SIZE B	PROJECT: MNXX	DWG NO MNBCB 2000-200	REV C
-----------	------------------	---------------------------------	----------

E-FILE: 14-MNBCB2000-1.iam SHEET 3 OF 5