



Rosie Parallel Wiring and Configuration Instructions (10-608-1 Rev D)

Overview

These instructions guide you through wiring and configuring the MNROSIE7048RE Inverter/Charger (“Rosie”) for parallel stacking. Each Rosie inverter produces 7000 watts of continuous power. When multiple Rosie inverters are stacked together in parallel, they function as a unified inverter/charger system. This configuration enhances continuous and surge capacity, boosts charging capability to the battery bank, and increases AC pass-through capacity.



WARNING: The information in these instructions is meant to supersede the AC stack wiring and stacking information provided in the MNROSIE7048RE Owner’s Manual (PN: 10-432-1) and the MNE300ROSIE-240P Manual (PN: 10-562-1).

You must carefully read and follow all safety instructions and cautionary markings specified in the manuals listed above and in these instructions. An incorrect installation may result in the risk of electric shock, fire, or other safety hazard; and/or equipment damage.



Info: For parallel stacking support, the Rosie inverter requires firmware version 24.10.22.3 or later, and the MNGP2 remote needs firmware version 24.10.16.00 or later.

Parallel System Requirements

When connecting units in parallel, the following requirements must be met:



Info: The Rosie Breaker Boxes used to Parallel Rosie’s (PN’s: MNE300ROSIE-240P100 and MNE300ROSIE-240F) meet the requirements needed to stack Rosie inverters and are UL listed (US) and CSA certified (Canada) for a code compliant installation.

- A Rosie parallel-stack power system requires at least two Rosie inverters wired together and an MNGP2¹ to configure each one. Currently, MidNite supports a maximum of two Rosie inverters connected in parallel.
- The MNGP2¹ remote must be directly connected to the CAN connection of one of the Rosie inverters to communicate and synchronize for parallel operation.
- Two communications cables—wired as a Cat5/Cat6 straight-thru/patch cable—should be connected to the CAN connectors: one is provided with the MNGP2 remote and another with the MNE300ROSIE-240P100 Breaker Box.
- Every inverter in the parallel system must be connected to the same battery bank.
- The DC connection cables from the battery to each inverter must be of equal length and size.
- There must be a separate cable run from each inverters positive terminal to the battery bank through a DC Disconnect and overcurrent protection device (i.e., breaker). **Note:** *If you connect the cables together—other than at a Battery Combiner—and a cable fails, there is a possibility of pulling too much current through the remaining cables.*
- The inverters’ negative terminals must be connected together, either at the inverters or at a location close to the inverters (within 18 inches/0.5 meters).
- The Rosie inverters should be no more than 6” (15 cm) from each other to allow the 6-foot communications cables to connect to each inverter, but allow at least 3” (7.6 cm) between, under, above, and in front of the inverter for ventilation purposes.
- The neutral outputs of all inverters are connected to the same neutral bus.
- The AC input to every inverter must be from the same AC source, and the two 120 VAC legs from that AC source into each inverter input must be 180° out-of-phase from each other.
- Each inverter must have appropriate AC and DC overcurrent protection.

Note 1: A MNGP2 is not required if a MidNite MNBCLNA or MNHAWKE’S BAY charge controller is also installed in the same system.

Parallel System Connections and Components

The basic installation procedure for a parallel system is similar to that of a single inverter system. However, the AC/DC connections and components required in a parallel system must be considered.

The AC and DC connections in a parallel system depend on additional separate components. The Rosie Breaker Boxes [e.g., MNE300ROSIE-240P100 (Primary) and MNE300ROSIE-240F (Follower)] are designed for a parallel system and include all these separate components (highlighted in **bold** in the sections below), with most of the necessary AC and DC wiring connections already completed for you.

The AC input supply to the parallel system must be a 120/240 VAC split-phase system that provides two line conductors (referred to as L1 and L2), a neutral, and a ground. The AC input to each Rosie inverter requires a double-pole circuit breaker rated for a maximum of 60 amps per pole. The Rosie Breaker Boxes provide the required separate **AC breakers** for the AC input of each Rosie inverter, and also includes the **AC terminals/busbars** to allow the connection of the neutral and ground conductors to each inverter input.

The AC output side of a parallel system requires AC terminals/busbars that combines all the inverter outputs and needs a large double-pole circuit breaker rated for the total output current of the parallel system. The Rosie Breaker Boxes, provide the full rated **AC output breaker**, along with a full system **AC bypass**. The AC Bypass is installed between the AC input and output connections to allow the AC source to continue powering the inverter loads when servicing batteries or in case of inverter failure.

When inverters are stacked, they must operate from the same battery bank. This means the DC negative of one inverter must be common with the second inverter, and likewise for the DC positive. Each inverter must be wired to the same battery bank separately and have a DC breaker on the positive side, matched to the cable size.

If the system requires battery bank monitoring, a full system DC shunt must be installed on the DC negative side. This can be done with a MidNite Solar Battery Combiner as shown in Figure 5.

Removing the Top Cover

A Rosie parallel-stack power system requires at least two Rosie inverters wired together and an MNGP2 to configure each one. Before programming the MNGP2 remote for parallel operation, use the following steps to remove the Rosie's top cover and wire the inverters.

To gain access to the Rosie CAN connectors and wire the Rosie, you'll need to remove the top cover. This is a straightforward process: simply unscrew the ten 10-32 Phillips-head screws, as shown in Figure 1.

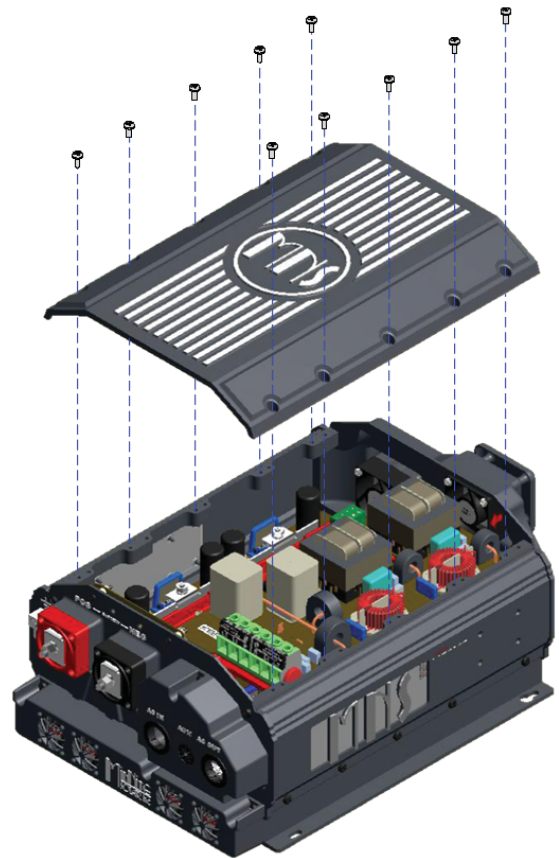

Figure 1, Removing the Top Cover

Rosie Communications

The MNGP2 remote and each Rosie inverter has two RJ45 connectors marked CAN IN and CAN OUT for ethernet cable connection. The ethernet cables, wired as a Cat5/Cat6 straight-thru/patch cable, allow multiple ROSIE inverters to communicate. The Rosie cable supports two separate network/bus sections: the CAN BUS section handles inverter/charger messaging, while the STK BUS section manages stacking messaging. Proper termination of each section is critical for maintaining signal/communication integrity, which is achieved by placing a termination resistor (i.e., Terminator) at the ends of each network/bus (see Figure 2).

IMPORTANT: As shown in Figure 2, terminators are only placed at the beginning and end of each network/bus. Ensure all devices between the beginning and end devices DO NOT have a terminator installed.

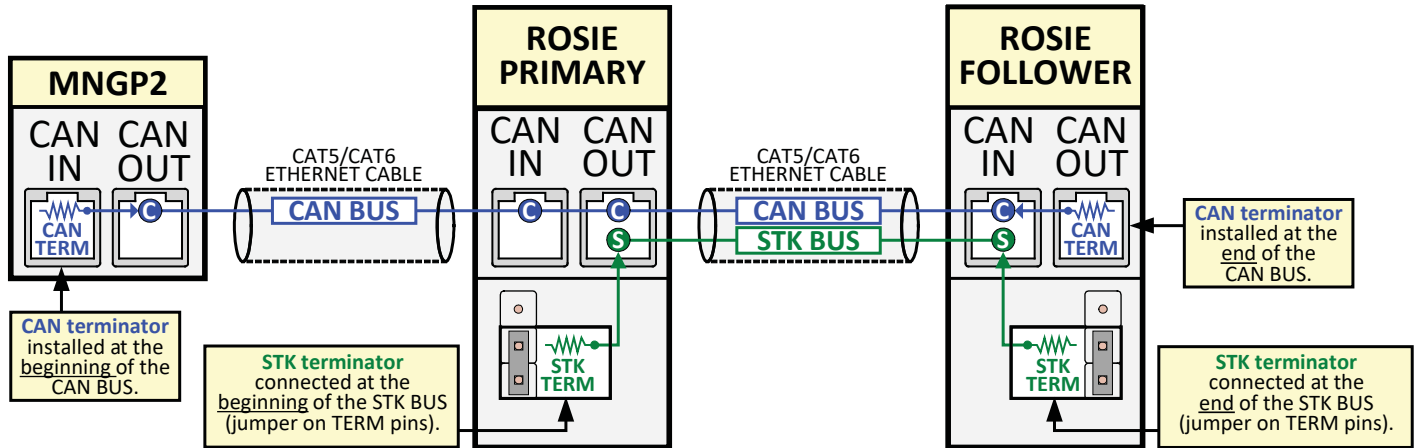

Figure 2, Properly Terminating the CAN and STK BUS Networks

Locating the CAN Connectors and the STK Terminating Jumper.

The MNGP2 remote has two RJ45 CAN connectors located on its backside. The Rosie inverter/charger has its two CAN connectors and the STK terminating jumper located inside, on the Front Panel PCBA as shown in Figure 3. While the top cover is off, it is recommended to check the jumper location to ensure the STK terminator is either connected (or not connected) as the installation requires.

Note: Normally the STK jumper is on the TERM pins (i.e., STK BUS is terminated) when shipped from MidNite.

Note: If using a BTS (Battery Temperature Sensor), its connector is also located on the Front Panel PCBA.

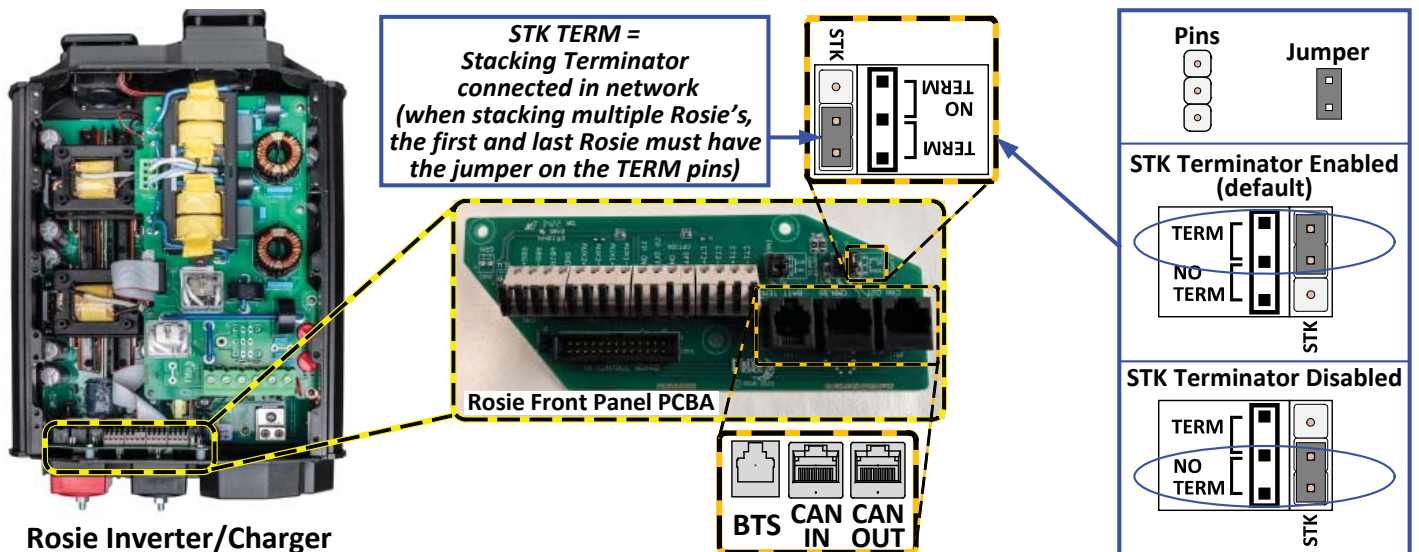

Figure 3, Locating the CAN Connectors

Parallel Stacking Diagram (AC Wiring)

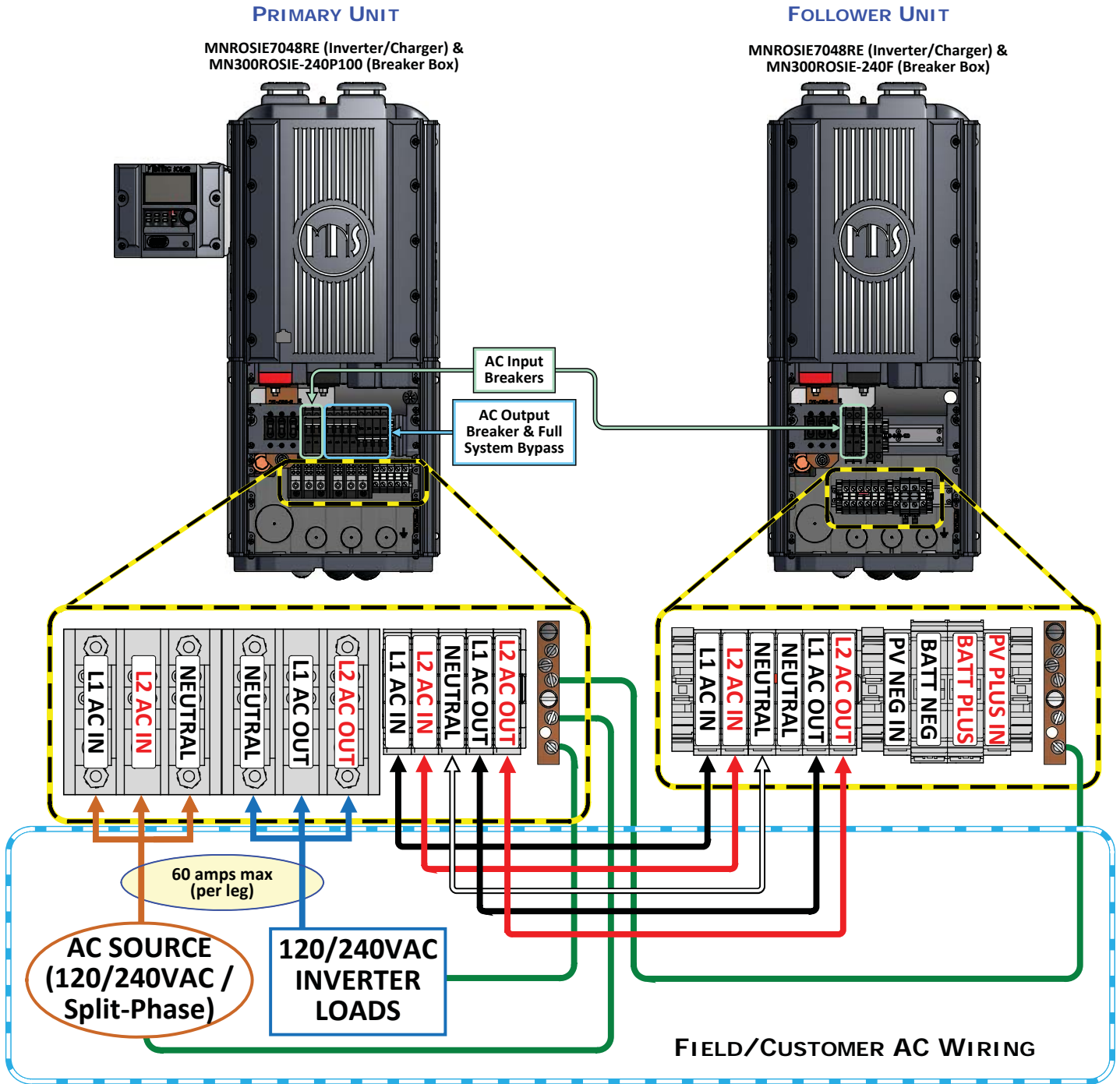

Figure 4, AC Wiring - Parallel Stacked Rosie Inverters

Parallel Stacking Diagram (DC Wiring with Open-Loop Communications)

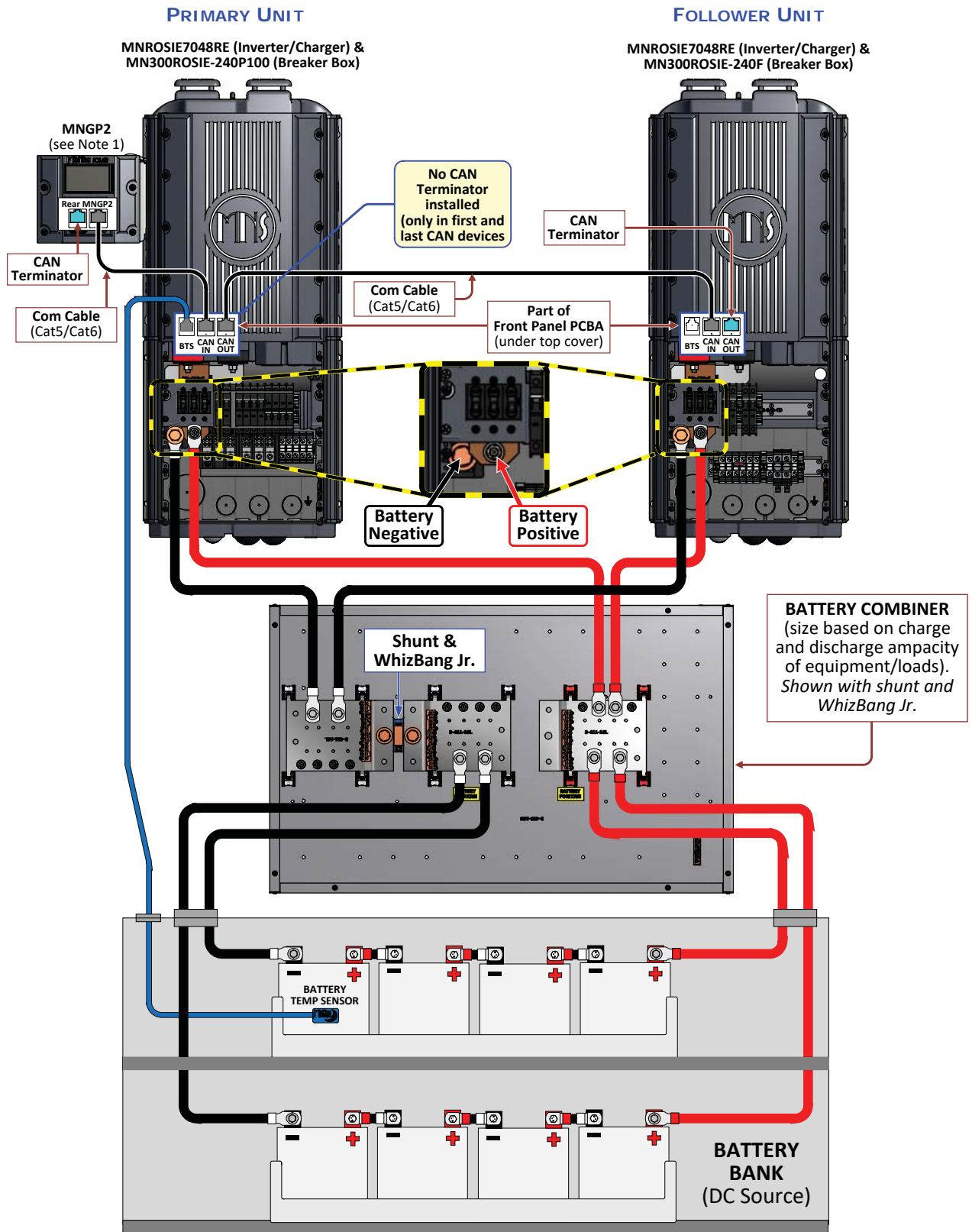

Figure 5, DC Wiring with Open-Loop Communications - Parallel Stacked Rosie Inverters

Parallel Stacking Diagram (DC Wiring with Closed-Loop Communications)

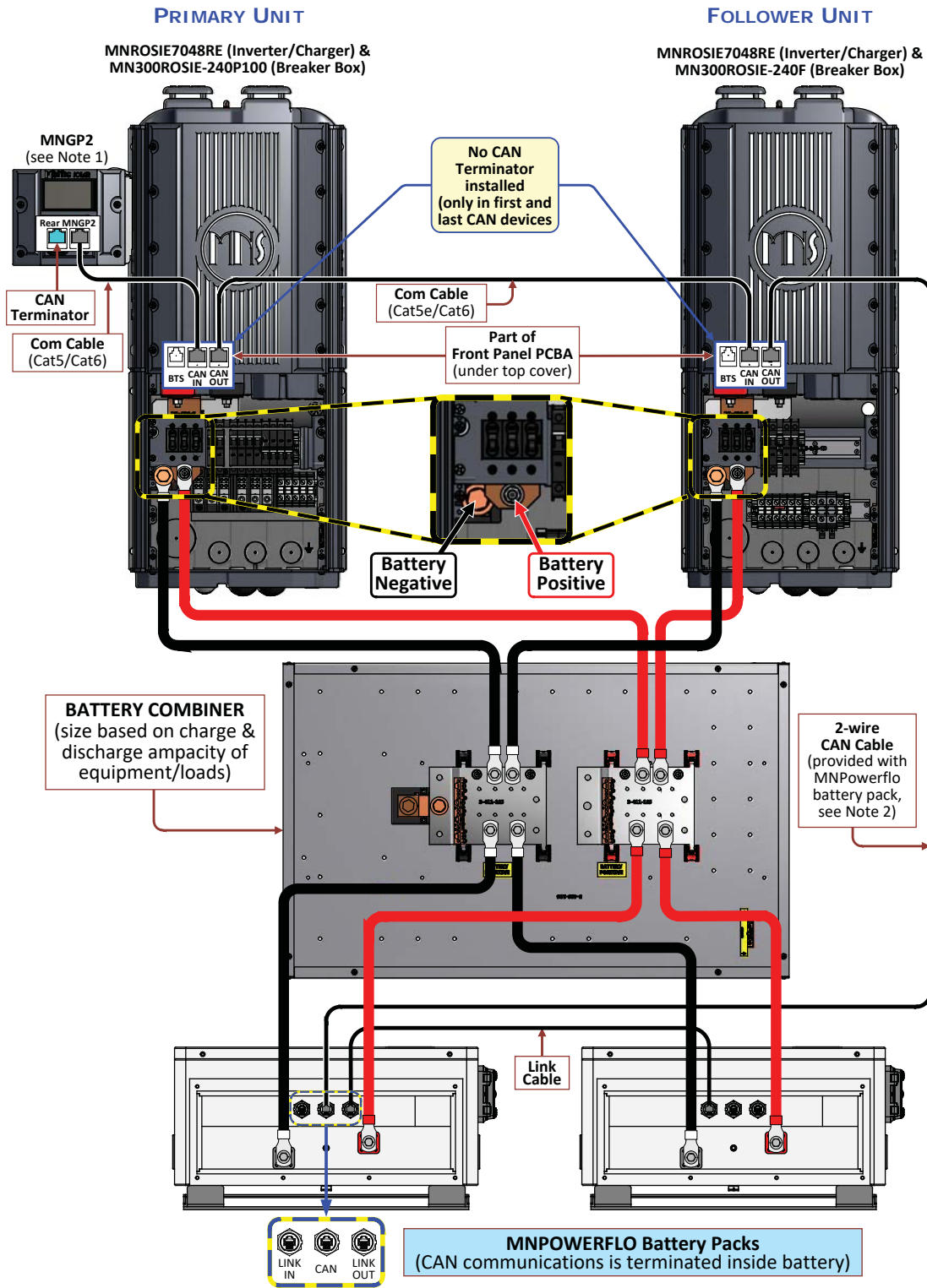

Figure 6, DC Wiring with Closed-Loop Communications - Parallel Stacked Rosie Inverters

Note 1. A MNGP2 is not required if a MidNite MNBCLNA or MNHAWKE'S BAY charge controller is also installed in the same system.

Note 2. When using more than one Rosie and with close-loop communications (e.g. using MidNite's MNPowerFlo battery), the 2-wire communications cable that comes with the battery will need to be plugged into one of the Rosie's (preferably the last Rosie), and ensure a CAN terminator is not plugged into that Rosie. The MNPowerFlo battery will be used to terminate one end of the CAN network.

Configuring the MNGP2 for Parallel Operation

This section provides information about configuring the Rosie inverters with the MNGP2 remote for parallel operation.

1. Power up the system at the battery breaker.
2. Reset the system to defaults using the MNGP2 and configure the battery settings.

User + **System Functions** >> **Set System to Defaults**  **Set System to Defaults**

3. The topology defaults to 120/240 60Hz in the System Config menu.
4. Name the inverters RosieA, RosieB, to help identify them.

Setup + **Inverter Config** >> **Inverter Specific** >> **Rosie** >> **Set Name**

5. You can use the aux output or the serial number to identify the units.

Setup + **Inverter Config** >> **Inverter Specific** >> **Rosie** >> **Firmware & Serial**

6. Set the first inverter to Leader + Parallel in the stacking menu (default).

Setup + **Inverter Config** >> **Inverter Specific** >> **RosieA** >> **Stacking** >> **Mode**  **Leader**

Setup + **Inverter Config** >> **Inverter Specific** >> **RosieA** >> **Stacking** >> **Phase**  **Parallel**

7. Set the other inverters to Follower + Parallel in the stacking menu.

Setup + **Inverter Config** >> **Inverter Specific** >> **RosieB** >> **Stacking** >> **Mode**  **Follower**

Setup + **Inverter Config** >> **Inverter Specific** >> **RosieB** >> **Stacking** >> **Phase**  **Parallel**

8. Configure charger and breaker current, this value is per inverter.

Note: The breaker size and current should be set to 1/N of the AC input breaker. N is the number of Rosies in parallel.

Setup + **Inverter Config** >> **AC Input** >> **Charge Rate**

Setup + **Inverter Config** >> **AC Input** >> **Breaker Size**

9. Reboot the system at the battery breaker and the stack will start inverting.
10. Turn on the AC input breaker and the stack will qualify and connect to the grid.