

# DUAL SUNNY ISLAND AC COUPLED WIRING INSTALLED BY MIDNITE SOLAR

**ALL WIRING #6  
UNLESS MARKED!!**

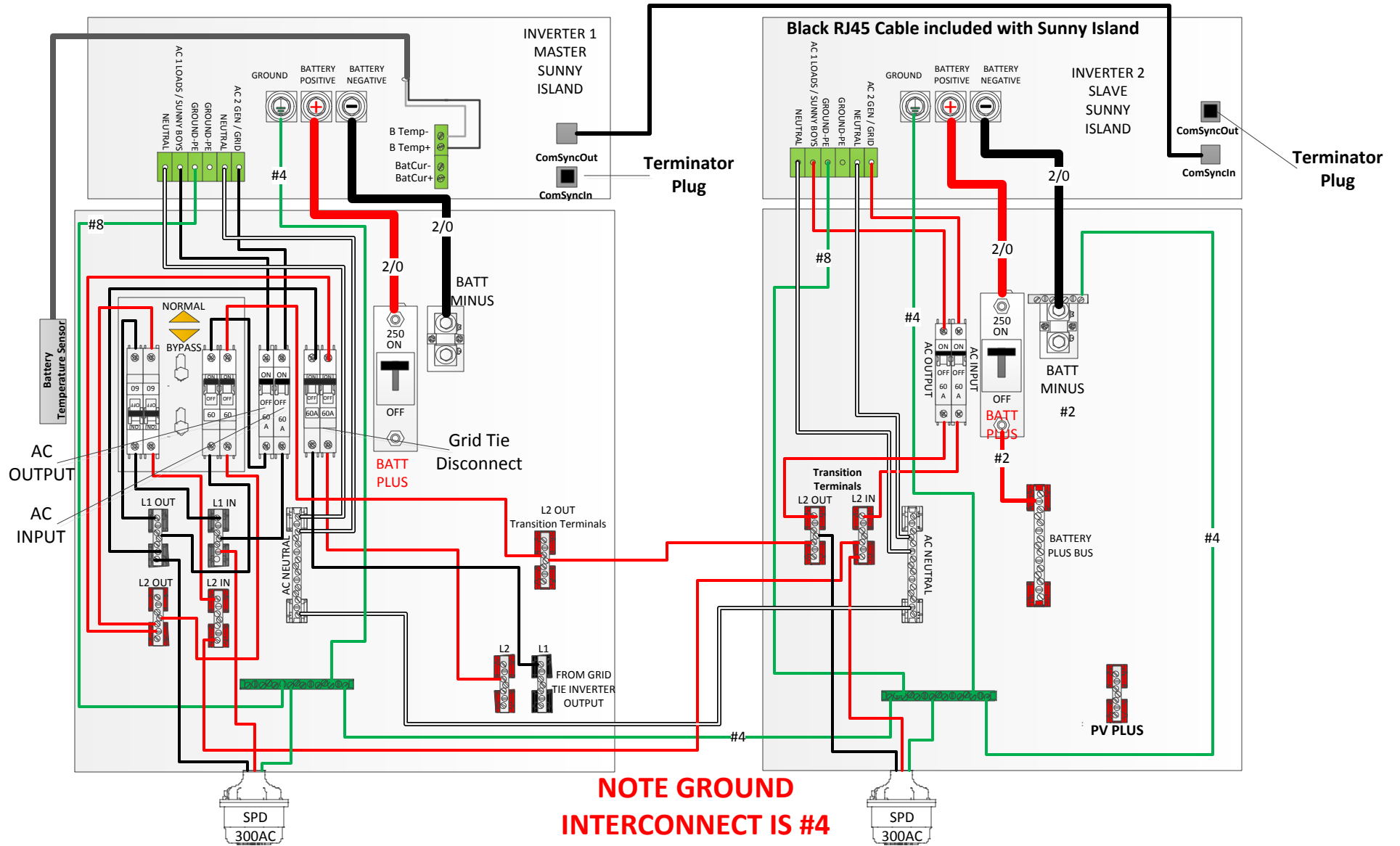

# MNSI6048D-ACCPL-RevD – 12/4/2014

## AC WIRING TO BE DONE BY CUSTOMER

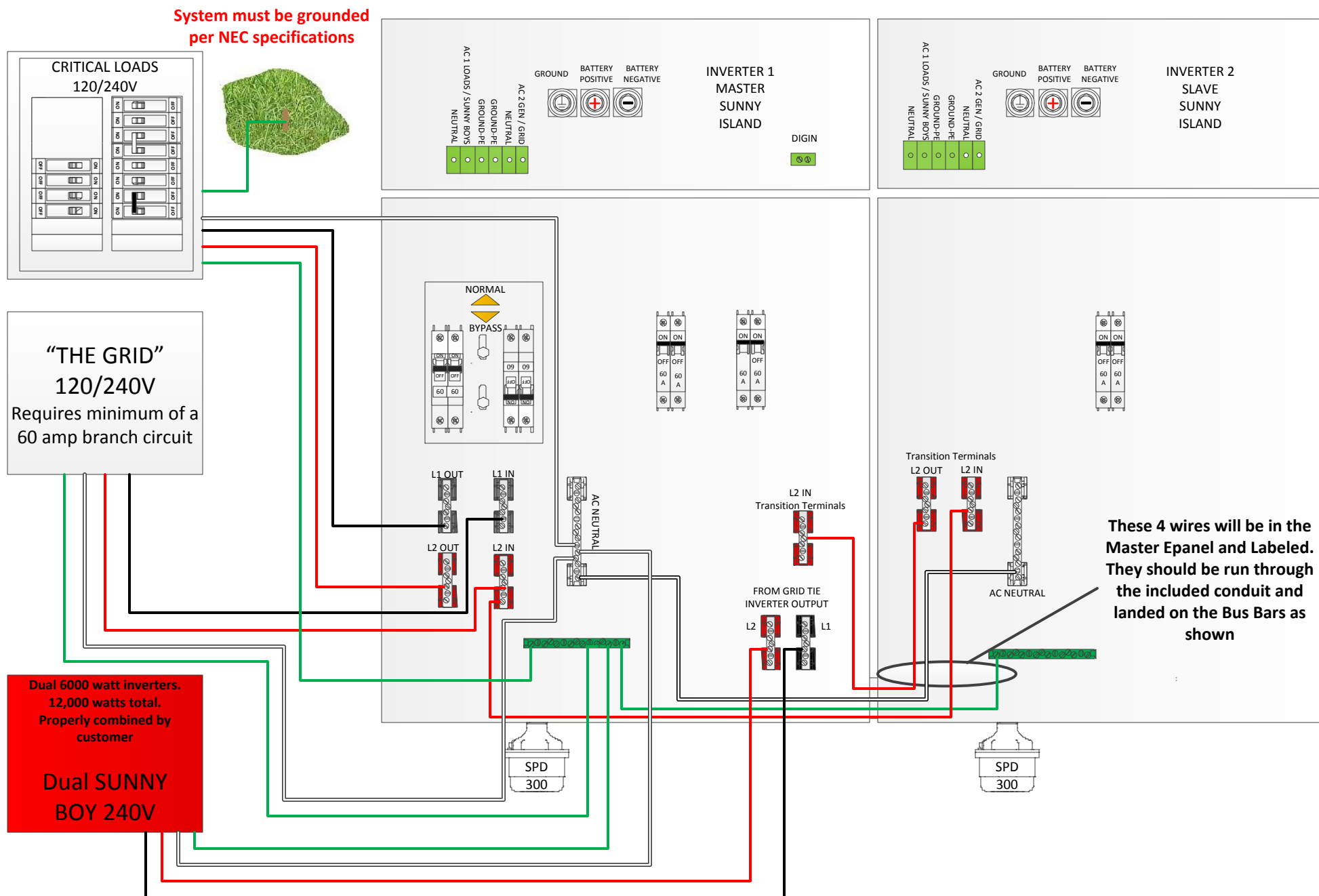

# MNSI6048D-ACCPL-RevD – 12/4/2014

## CUSTOMER DC AND COMMUNICATIONS WIRING

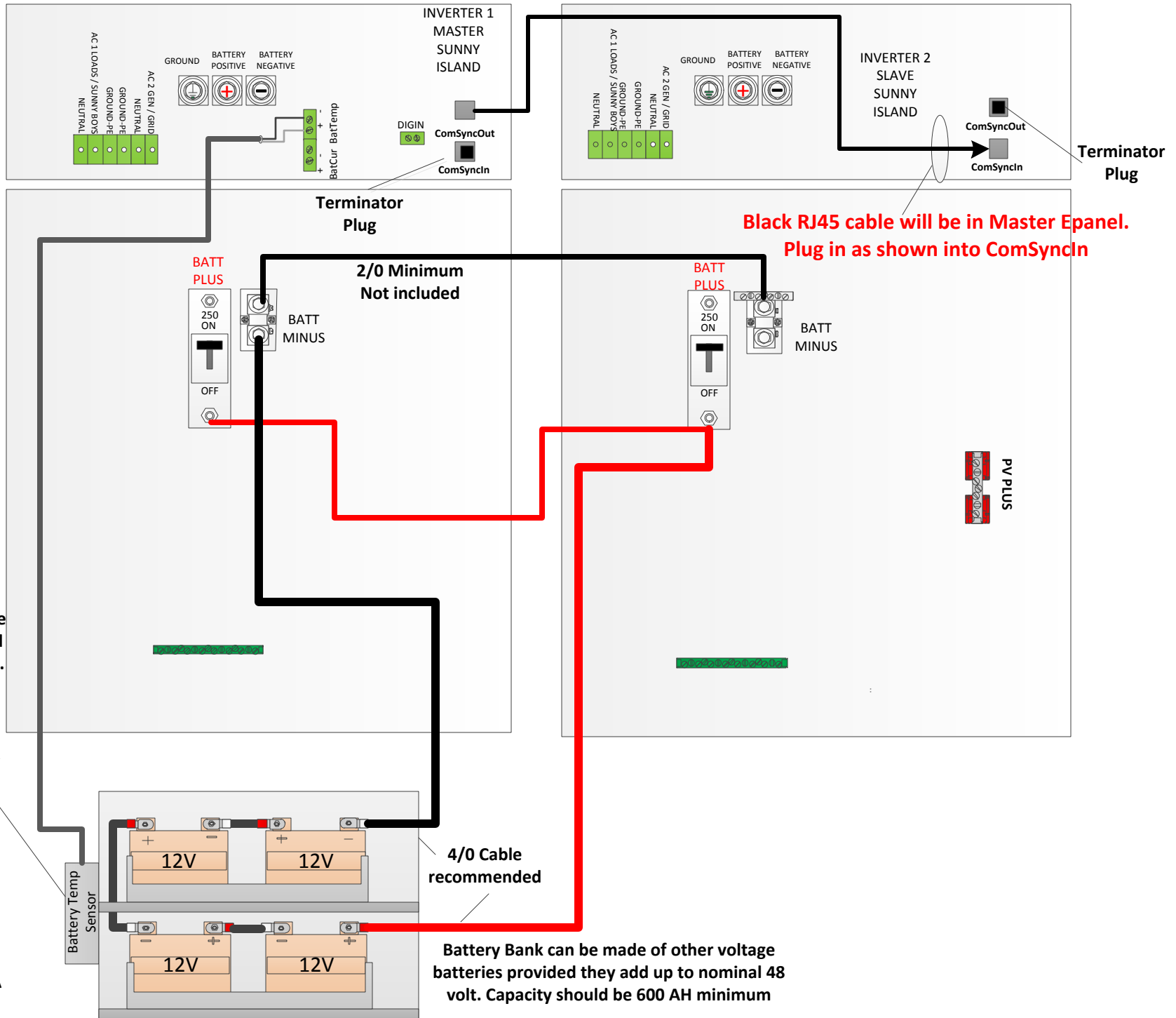

Battery Temperature sensor will be coiled up in Master Epanel. Attach to battery bank per SMA's Specifications on Page 51 of the SMA Manual