



MNPVHV Disco Instructions

MidNite Solar Inc.
19115 – 62nd Ave NE
Arlington, WA 98223
www.midnitesolar.com



MNPV8HV-DISCO 4X



MNPV6HV-DISCO 4X

MNPVHV disconnecting-combiners are rated for outdoor use. Designed for combining high voltage strings using 10mm x 38mm fuses. The use of touch-safe din rail mount fuses and fuseholders allows operation up to 600V.

This Manual covers the following models:

- MNPV4HV-DISCO 3R
- MNPV6HV-DISCO 4X
- MNPV8HV-DISCO 4X
- MNPV8HV-DISCO 3R
- MNPV16HV-DISCO 4X
- MNPVHV8-DLTL 3R
- MNPVHV8-DLTL 4X
- MNPVHV16-DLTL 4X

Features:

- Outdoor enclosures available in Type 3R and Type 4X
- Powder-coated aluminum construction stands up to the elements
- Type 4X units are waterproof in any orientation
- Combiners are designed for use with one or two inverters
- “Convertible” design allows for great flexibility
- Big Red Handle makes for easy to understand operation
- Clear deadfront cover provides safety and a look inside
- Additional remote disconnects can be added – any remote can turn off all combiners
- Compatible with the Birdhouse for remote disconnect and other features (sold separately)
- Meets and exceeds NEC 2011 requirements

IMPORTANT SAFETY INSTRUCTIONS

SAVE THESE INSTRUCTIONS

These instructions contain important safety and operating instructions for the MidNite Solar MNPVHV Disconnecting Combiner boxes.

If you do not fully understand any of the concepts, terminology, or hazards outlined in these instructions, please refer installation to a qualified dealer, electrician, or installer. These instructions are not meant to be a complete explanation of a renewable energy system.

GENERAL PRECAUTIONS

If service or repair should become necessary, contact MidNite Solar Inc. Improper servicing may result in a risk of shock, fire or explosion. To reduce these risks, disconnect all wiring before attempting any maintenance or cleaning. Turning off the inverter will not reduce these risks. Solar modules produce power when exposed to light. When it is not possible to disconnect the power coming from the photovoltaics by an external means such as a combiner, cover the modules with an opaque material before servicing any connected equipment.

Do not work alone. Someone should be in the range of your voice or close enough to come to your aid when you work with or near electrical equipment.

Remove rings, bracelets, necklaces, watches etc. when working with photovoltaic modules or other electrical equipment. Power from an illuminated photovoltaic array makes a very effective arc welder with dire consequences if one of the welded pieces is on your person.

INSTRUCTIONS DE SECURITÉ IMPORTANTES

CONSERVER CES INSTRUCTIONS

Ces instructions contiennent des informations importantes pour utiliser le MidNite Solar SMA MNX-240 Autotransformer en toute sécurité.

1. Avant l'utilisez cet appareil lisez et comprenez toutes les instructions et avertissements.
2. Si vous ne comprenez pas l'une des concepts ou des instructions contenu dans ce manuel consulter un agent spécialisé.
3. Si des réparations sont nécessaires contactez MidNite Solar pour plus des informations. Danger de choc électrique et de risque de brûlure. Rien à dépanner à l'intérieur de cet appareil. Ne pas ouvrir le couvercle. Pour toute réparation ou service d'entretien, consulter un agent spécialisé. Il y a peut-être plusieurs sources d'alimentation dans ce système. Débrancher toutes les interrupteurs avant toute d'entretien ou nettoyage.
4. Ne travaillez pas seul. Quelqu'un devrait toujours être à proximité pour aider en cas d'une situation d'urgence.
5. Retirer bagues, bracelets, colliers, montres, et autres choses comme ça. Il y a risque des blessures graves s'il y a un court-circuit. Cela pourrait ruiner votre journée entière.
6. Le câblage doit être fait en conformité avec le National Electrical Code ANSI / NFPA 70. Utiliser des méthodes de câblage de catégorie 1 pour les connexions de câblage sur des terminaux d'un circuit de classe 2. Utilisez uniquement des fils de AWM de calibre 14-1/0. Sélectionnez le type de câble utilisé sur la base de la protection prévue par les disjoncteurs / fusibles.

Table of Contents

Introduction.....	4
Installation.....	4
Wire Torque Requirements	5
Reconfiguring Combiners	7
MNPVHV4 and MNPVHV6 Combiners	16
MNPVHV8-DLTL and MNPVHV16-DLTL Combiners.....	17
MNSPD	18
Wiring.....	20
Optional Accessories.....	24
Installing the MNDISCOPSB.....	25
Knockout Locations.....	31
Warranty.....	36
Contact Information.....	36

Disclaimer of Liability

MidNite products are not intended for use in connection with Life Support Systems. MidNite Solar makes no warranty or representation in connection with their products for such uses.

Since the use of this manual and the conditions or methods of installation, operation, use of the Combiner(s) are beyond the control of MidNite Solar, this company does not assume responsibility and expressly disclaims liability for loss, damage or expense, whether direct, indirect, consequential or incidental, arising out of or anyway connected with such installation, operation, or use.

Unless specifically agreed to in writing, MidNite Solar Inc.

- (a) Makes no warranty as to the accuracy, sufficiency, or suitability of any technical or other information provided in its manuals or other documentation.
- (b) Assumes no responsibility or liability for loss or damage whether direct, indirect, consequential or incidental, which might arise out of use of such information. The use of any such information will be entirely at the user's risk.

Introduction

The MNPVHV series of combiners are designed for indoor / outdoor use. Type 4X have been tested to be watertight to 2 meters underwater, so they are sure to be watertight above sea level. The MNPV4HV and MNPV6HV are basic disconnecting combiners while the MNPV8HV and MNPV16HV are reconfigurable to accommodate non-isolated inverters or to divide one combiner into two separate halves to power two inverters.

Overview of size and ratings:

MNPVHV4-DISCO 3R	4 position, 80A, NEMA 3R
MNPVHV6-DISCO 4X	6 position, 100A, NEMA 4X
MNPVHV8-DISCO 3R MNPVHV8-DISCO 4X	8 position, 100/200A, NEMA 3R or 4X, configurable as 4 plus and 4 minus positions for non-isolated inverters
MNPVHV16-DISCO 4X	16 position, 200A, NEMA 4X, configurable as 8 plus and 8 minus positions for non-isolated inverters
MNPVHV8-DLTL 3R or 4X	4 plus and 4 minus positions for non-isolated inverters NEMA 4X 4 plus and 4 minus positions for non-isolated inverters NEMA 3R
MNPVHV16-DLTL 4X	8 plus and 8 minus positions for non-isolated inverters NEMA 4X 8 plus and 8 minus positions for non-isolated inverters NEMA 3R

Installation

To Remove the Deadfront:

On 3R type units, pry off the lid as shown using a screwdriver as a lever. The dead front then lifts out easily.

Note: The plastic dead front fits very tight. You must first remove the lid in order to remove the deadfront.

On TYPE 4X units the deadfront is secured to the busbars just above the fuse holders. To remove it, gently lift it out from the top. Removing the door is not necessary.

To Reinstall the Deadfront (on all units):

Press it gently into place. There will be a gentle snap when it seats.

To Install the Combiner:

Select the location to install your combiner. Some systems have the PV modules located close to the inverters. If this is the case, you can elect to mount the MNPV inside and run each PV string down to the MNPV inside the building. This is convenient for trouble shooting and upgrading. For longer runs the combiner will be mounted outdoors on the pole for pole mounted PV arrays or similar mounting for rack-mounted arrays. Combiners with a TYPE 3R enclosure can be mounted in the vertical position or slanted backwards to accommodate up to a 3/12 (14°) roof pitch. All unused holes should be blocked using RTV sealant or something similar in order to keep rain and insects out of the enclosure. Care must be taken to ensure no water will get on terminal busbars or fuse holders when mounted less than vertical. Type 4X units are submersible to two meters in any orientation, so it



Remove top cover prior to removing the deadfront on Type 3R units.

MNPVHV Disco Instructions (continued)

will certainly be watertight above sea level. Be sure to comply with all local and national code requirements including National Electrical Code, ANSI/NFPA 70. Use Class 1 wiring methods for field wiring connections to terminals of a Class 2 circuit. Use only #14 - #1/0 gauge AWM wire. Select the wire gauge used based on the protection provided by the circuit breakers/fuses. Combiners should be mounted with #10 or larger stainless steel hardware.

There are various wiring diagrams and system examples available at www.midnitesolar.com. Click on Documents at the top of the page for links to wiring diagrams in PDF as well as links to AutoCad wiring diagrams and even solid models aimed at aiding the system installer and designer. As such we request that they not be used for any other purpose.

Caution! Do not disconnect any cables under load. Remove power prior to connecting or disconnecting any cable connections. If necessary, cover the solar panels with opaque material to remove power. Extremely bad things **WILL** happen if connections are opened under load.

Torque – Fuseholder USM1 Fuse holder 15 in-lbs (1.7Nm)		Torque – Various Screws/Bolts	
Torque – Terminal Bus Bar		8-32	20 in-lbs (2.3Nm)
		1/4-20	80 in-lbs (9.1Nm)
		Torque – Large Box Lug	
10AWG	20 in-lbs (2.3Nm)	300 MCM	275 in-lbs (23.1 NM)
8AWG	25 in-lbs (2.8Nm)		
6AWG	35 in-lbs (4.0Nm)		
4AWG	45 in-lbs (5.1Nm)		
2AWG – 1/0	50 in-lbs (5.6Nm)		

Recommended Torque Values

These values apply to all the bus bars and the Plus output box lug up to #2/0. Re-torque fuseholders after one hour.

The MidNite MNPVHV combiners utilize touch safe fuse holders and fuses rated for up to 600VDC. The MNPV8HV can accommodate eight USM1 type fuse holders made by Ferraz Shawmut or other compatible fuse holders. Fuses are available from 1 to 30A. (The combiners come with 15A fuses installed except special built).

Do not open the fuseholders under load.
You **WILL** have a fire on your hands!



Ferraz Shawmut
USM1 Touch Safe fuseholder
Midnite Solar part number -
MNTS



Enclosure Notes:

In order to ensure water-tightness on Type 4X units and rain-tightness on the Type 3R units, it is important to install connectors or hole plugs into every opening. Silicone sealant can be used to plug all openings on Type 3R units except for the two 1/8" drain holes on the bottom.

On Type 4X units two 1/8" drain holes can be placed at the lowest point on the enclosure. The enclosure will not be as water-tight, but this will give any condensation that may build up a way out of the enclosure.

MNPVHV Disco Instructions (continued)



MNPV16HV-DISCO 4X bottom shown with plugs

Tighten firmly with tool available from MidNite Solar

Tighten hole plugs firmly on 4X units with MidNite Solar tool part number 5-151-1 (included). Tighten from the inside of the combiner to avoid twisting the gasket.

Tighten from the inside of the combiner

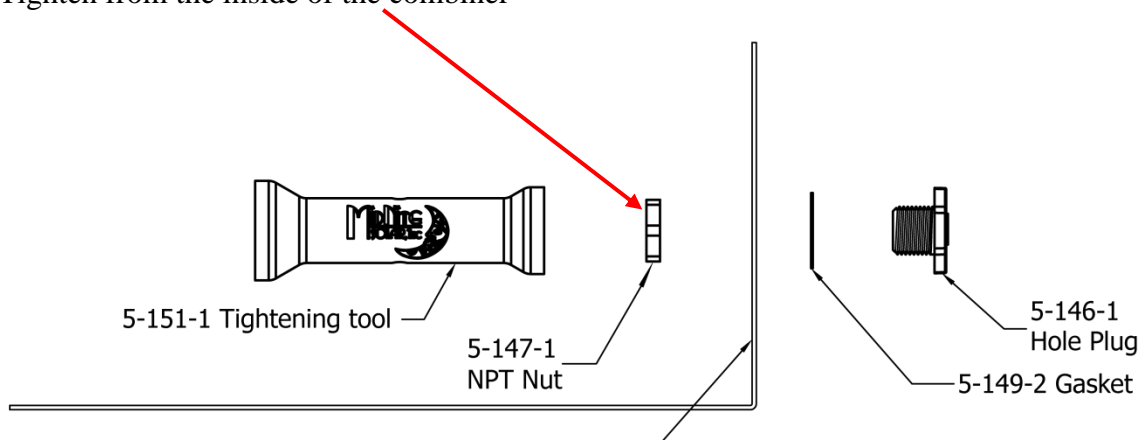

Hole plug parts placement on Type 4X Chassis

NOTE: Seal all conduit openings inside the SOB with sealant (Duct Seal, etc.) to prevent moisture intrusion. Conduits act like ductwork, carrying warm, moisture-laden air into the enclosures, causing condensation which can damage internal components. This is especially true in colder weather where the conduit is heated by the sun and the 4X box is cold. Moisture condenses on all interior surfaces; it has nowhere to go.

Reconfiguring MNPVHV Combiners

MNPVHV Combiners come complete with all the busbars and additional labels required to reconfigure to any of the three possible configurations: Non-Isolated, 2-Inverter, and Parallel. All combiners are shipped from the factory setup as parallel.

Tools required:

#2 Phillips screwdriver

5/16", 3/8", and 7/16" wrenches

Slotted screwdriver

Crimper for MNSPD ring lugs (If needed)

Configurations Defined:

Parallel: In this mode the negative input busbars are joined into a single unit and the positive outputs are joined at the disconnect providing an 8- (MNPV8HV) or 16- (MNPVHV16) string combiner. This is the default configuration.

Inverters: In this mode the negative input busbars are separate as are the positive outputs providing two separate 4- (MNPV8HV) or 8- (MNPVHV16) string combiners with a single 2-pole disconnect.

Non-Isolated: In this mode the negative input busbars are not used, rather the negative inputs go directly to the fuseholders on the left and the positive inputs go to the fuseholders on the right. This provides a 4- (MNPV8HV) or 8- (MNPVHV16) string combiner fused on the negative as well as on the positive with a single 2-pole disconnect as required for a non-isolated installation.

MNPV16HV

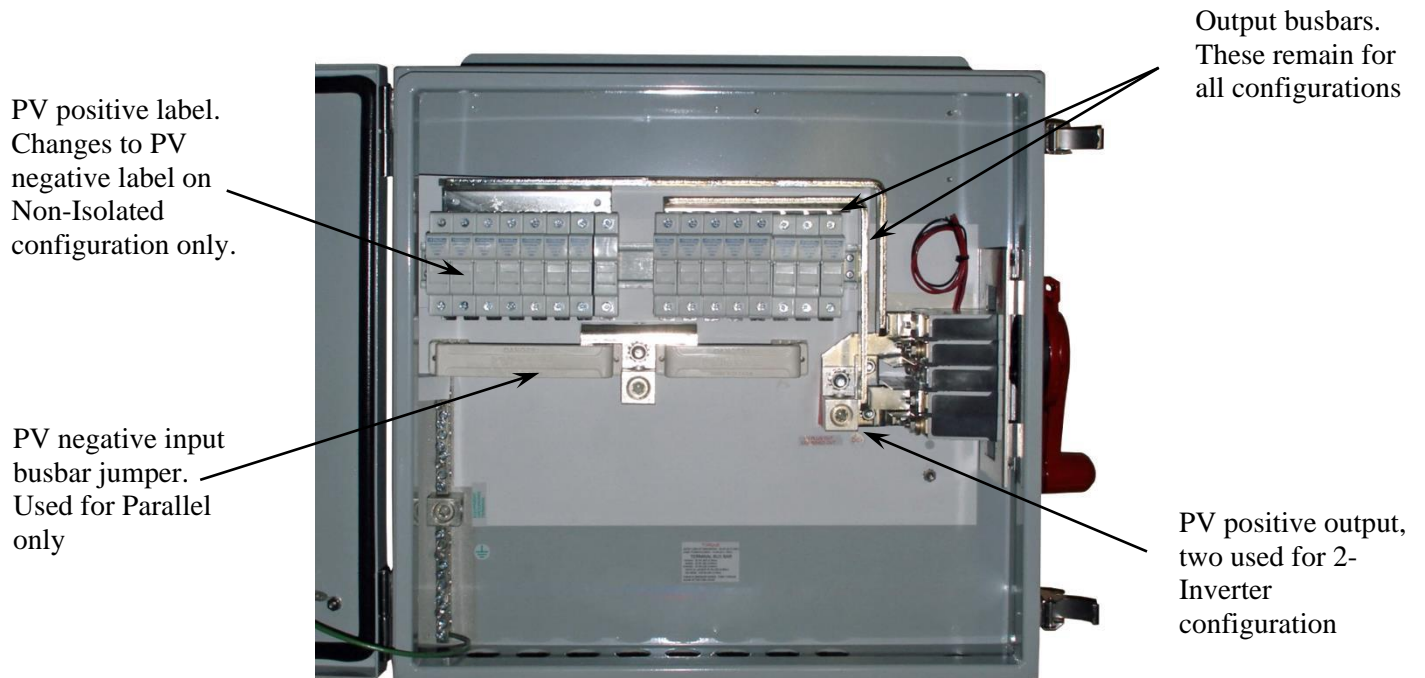

**MNPV16HV Parallel configuration (default)
16-string Disconnecting Combiner**

MNPVHV Disco Instructions (continued)

The following instructions assume starting from the default (parallel) configuration. If starting from another setup then either revert to the default (Parallel) configuration or follow the instructions for the desired configuration bearing in mind that the instructions may ask you to add/remove a busbar or label that has already been added/removed. If reverting back to parallel follow the instructions for the current configuration in reverse.

NOTE: The MNPV16HV DISCO is a discontinued product, no longer manufactured by MidNite Solar.

Components supplied for reconfiguring MNPV16HV (See page 30 for quantities):

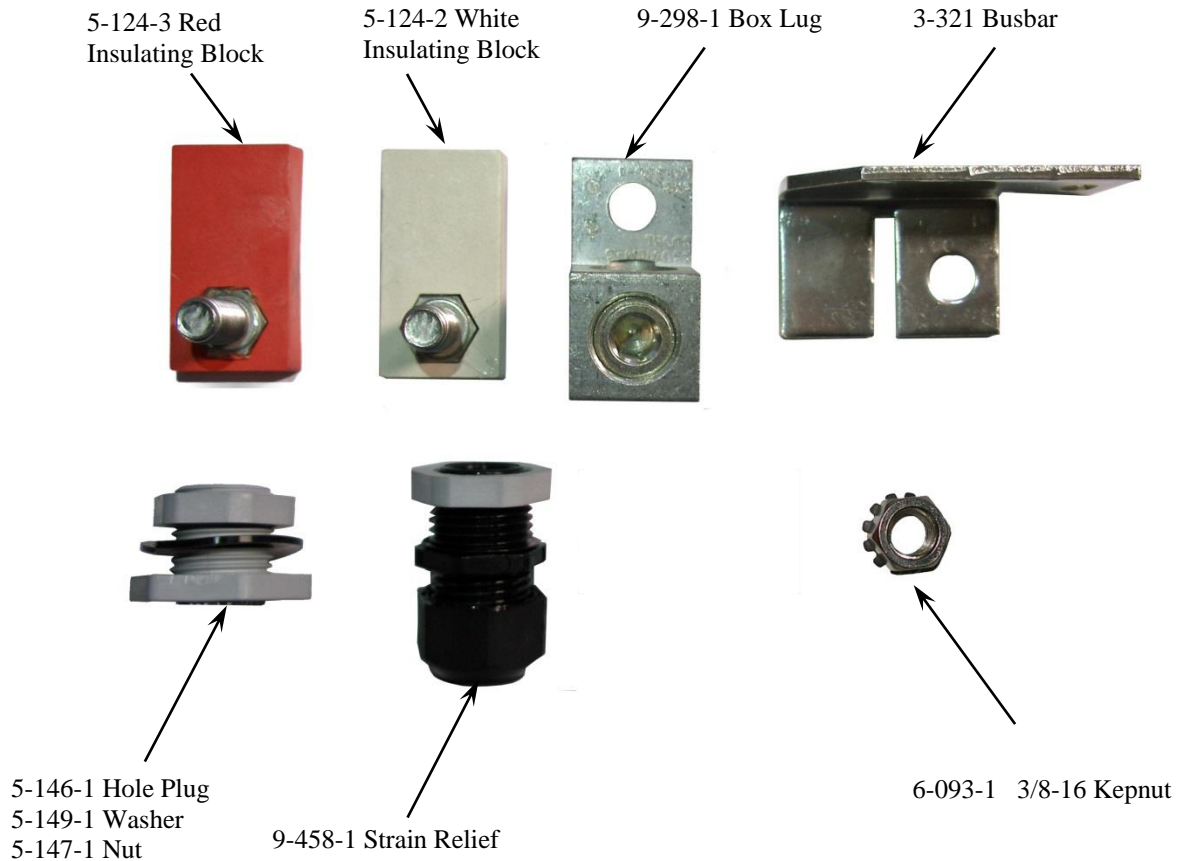

The parts above (included) are all that is required to convert the MNPV16HV Combiner to any of its configurations.

On TYPE 4X units a special sealing screw is used to ensure that the unit is water-tight. Use of other screw types will compromise the seal and should not be used.



MNPV16HV (cont)

Reconfiguring Parallel to 2 Inverters / Non-Isolated:

Step 1: Remove PV negative block

Change left “PV POSITIVE” label to “PV NEGATIVE” on Non-Isolated configuration only.

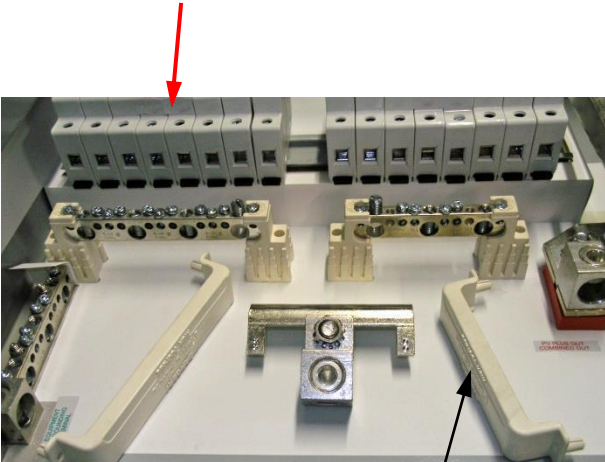

Remove terminal block covers by lifting gently

Step 2: Remove PV positive combined out and negative box lugs

Remove PV negative output lug and set aside. It is not used in the 2 Inverter/Non-Isolated configuration.

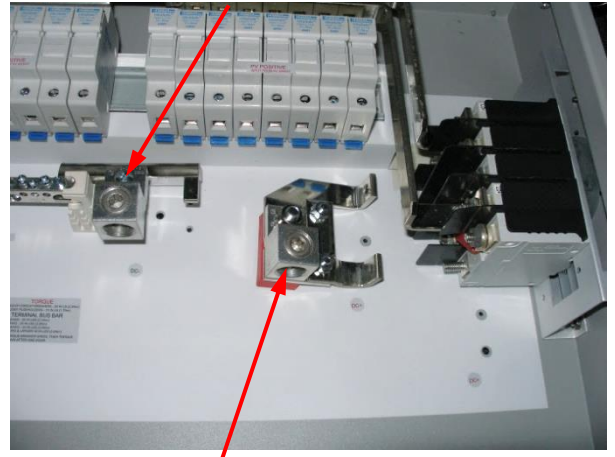

Remove PV positive Combined Out lug by removing nuts on breakers. It will be reinstalled in Step 4

Step 3: Remove small busbar from PV positive Combined Out lug.



Remove two bolts holding small busbar.
Remove small busbar from PV positive lug

Step 4: Reinstall PV positive box lug.
Replace red insulator block with a white one.

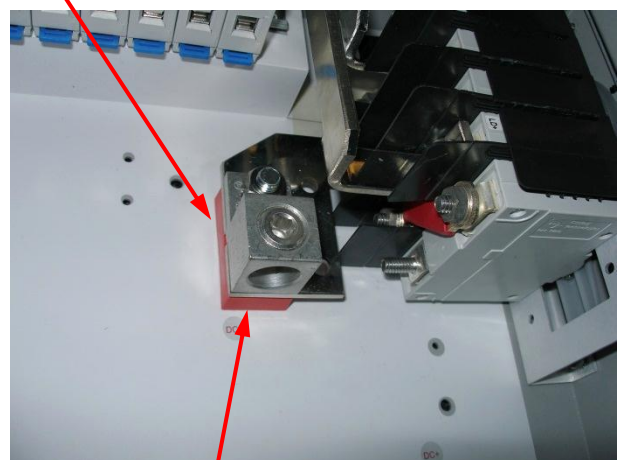

Reinstall PV positive output box lug in its original position using a 7/16” boxwrench. See torque chart on Page 5. Install sealed 10-32 X 3/8 screw through bottom into red insulator brass insert

MNPV16HV (cont)

Step 5: Install PV Positive box lug

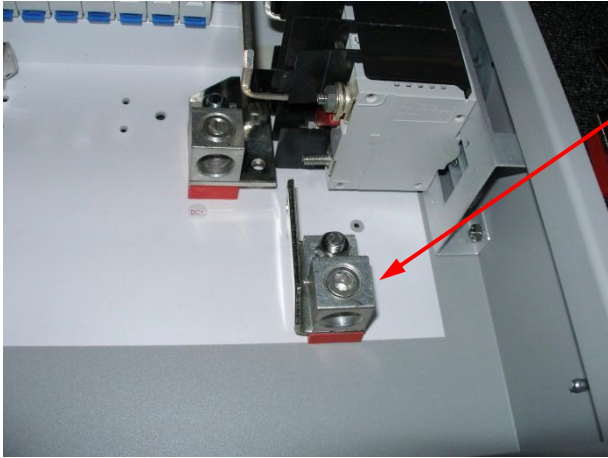

Install PV positive output box lug on bottom position of switch. See torque chart on Page 5. Finally, replace the PV negative busbar removed in Step 1 and install busbar.

Leftover parts should include the Non-Isolated Negative busbar, the PV negative lug removed in Step 2 and the small busbar removed in Step 3

When you finish the conversion, compare your result with the photo below to be sure that all steps were completed correctly. You should now have two separate, 8-string combiners in one box

MNPV16HV 2-Inverter Reconfiguration Checklist

Label changed to "PV NEGATIVE" on Non-Isolated units only.

PV negative output lug removed.

Shorting busbar removed from PV positive output lug

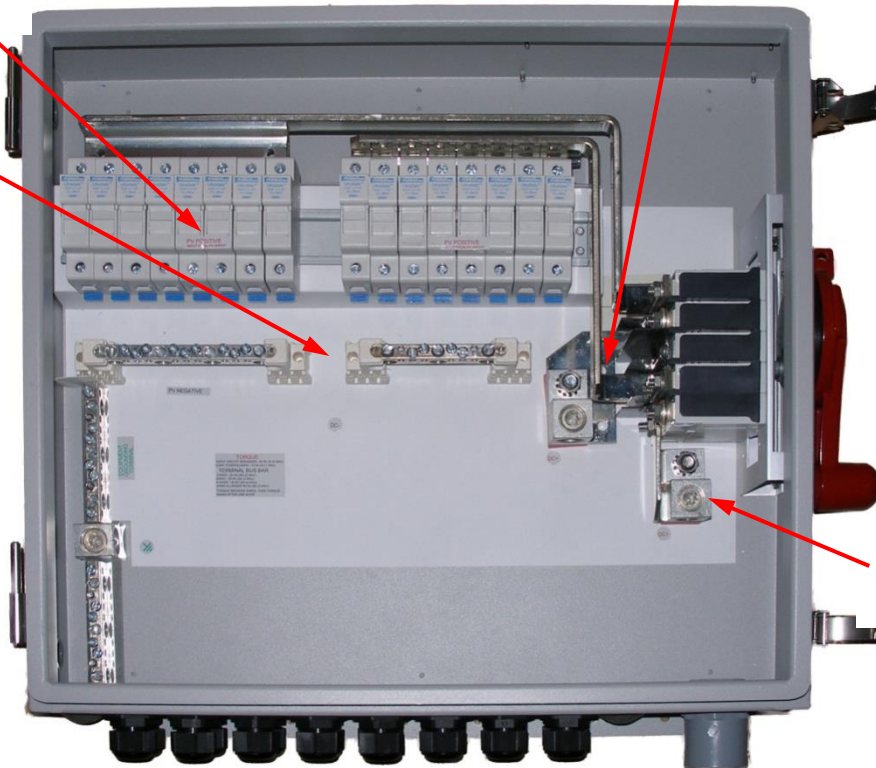

Second PV positive output lug installed

MNPV16HV Configured for 2-Inverters / Non-Isolated

MNPV8HV

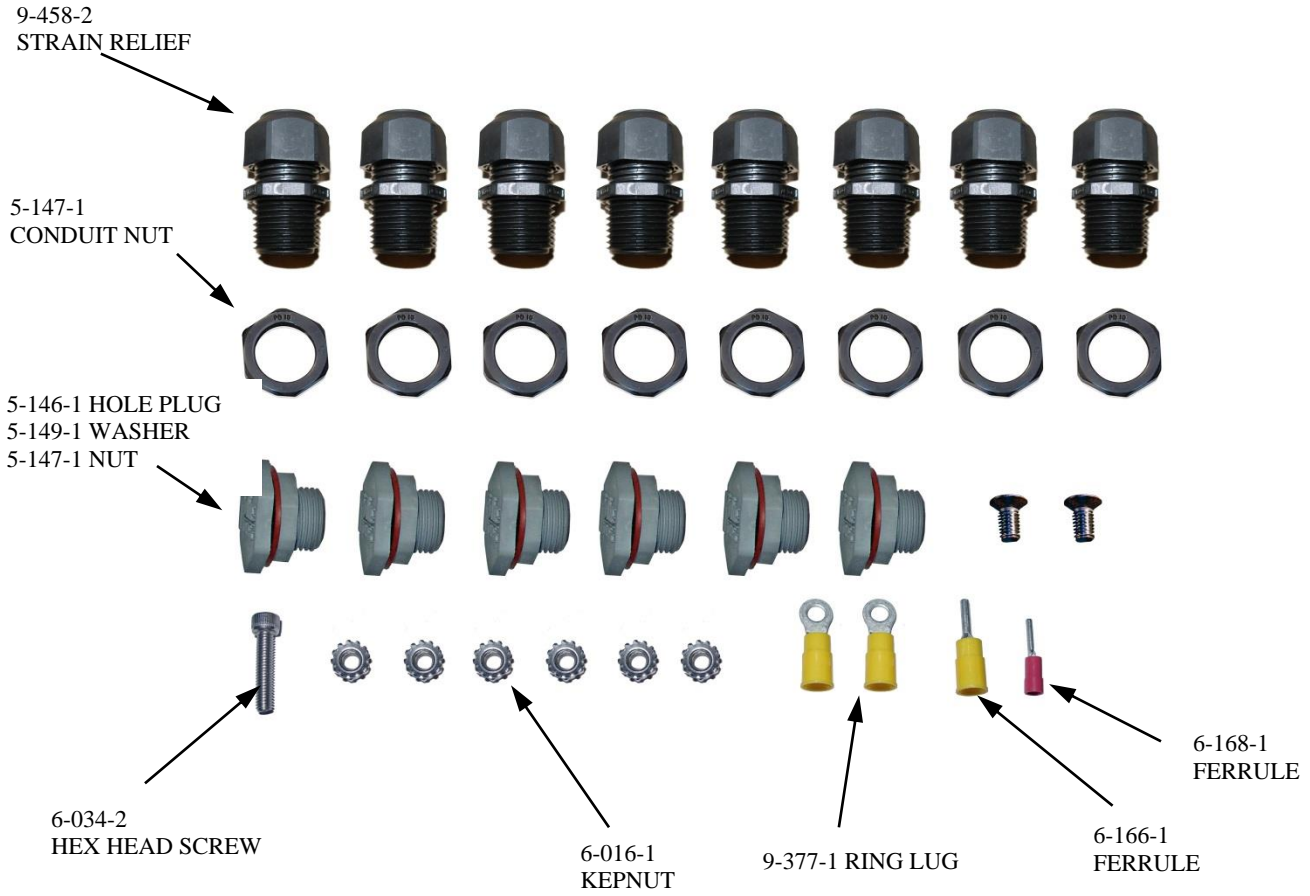

MNPV8HV Hardware Kit

MNPV8HV (cont)

These additional busbars supplied with the MNPV8HV Combiner are all that is needed to convert it to any of its configurations

PV positive busbar for 2-Inverter configuration

PV negative busbar for Non-Isolated configuration



Reconfiguring Parallel to 2-Inverters:

NOTE: The MNPV8HV TYPE 4X is shown, but the process is the same for the MNPV8HV TYPE 3R.

Step 1: Remove Output blocks and Negative jumper busbar

Step 2: Remove Parallel Positive Output busbar

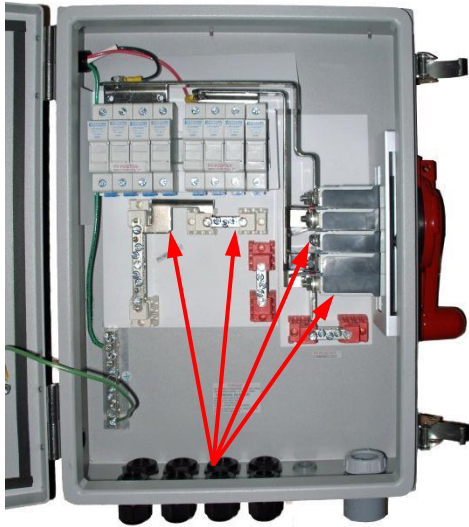

Remove positive and negative terminal blocks and the Negative jumper busbar as shown.

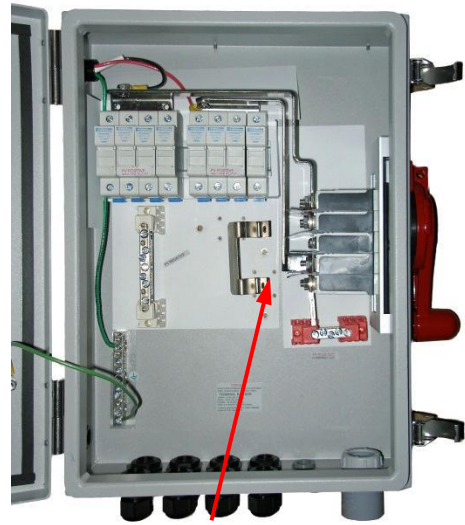

Remove Positive jumper busbar from switch, set aside, it is not used in this configuration. Replace nut on lowest position only.

Step 3: Install Positive Output busbar

Step 3 (cont): Install Positive Output busbar

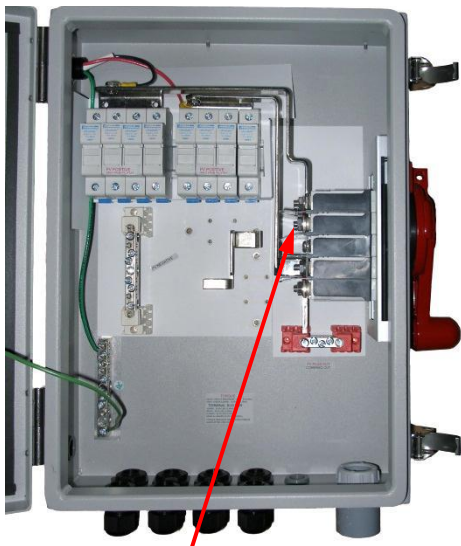

Install Supplied PV Positive busbar for 2 inverter configuration. Oriented as shown.

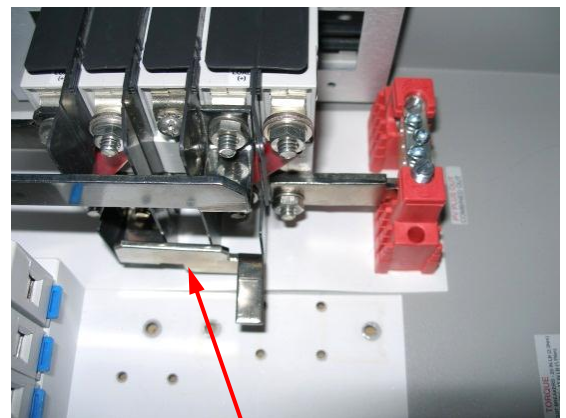

Busbar shown installed

MNPV8HV (cont)

Step 4: Reinstall Positive block

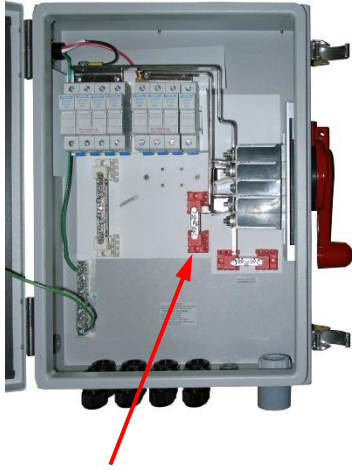

Install block. Refer to torque chart on Page 5. Use screws removed in Step 1

Step 5: Reinstall Negative block

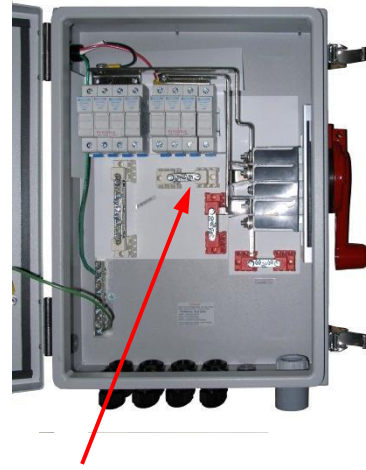

Install block. Refer to torque chart on Page 5. Use screws removed in Step 1.

MNPV8HV 2 Inverter Reconfiguration Checklist

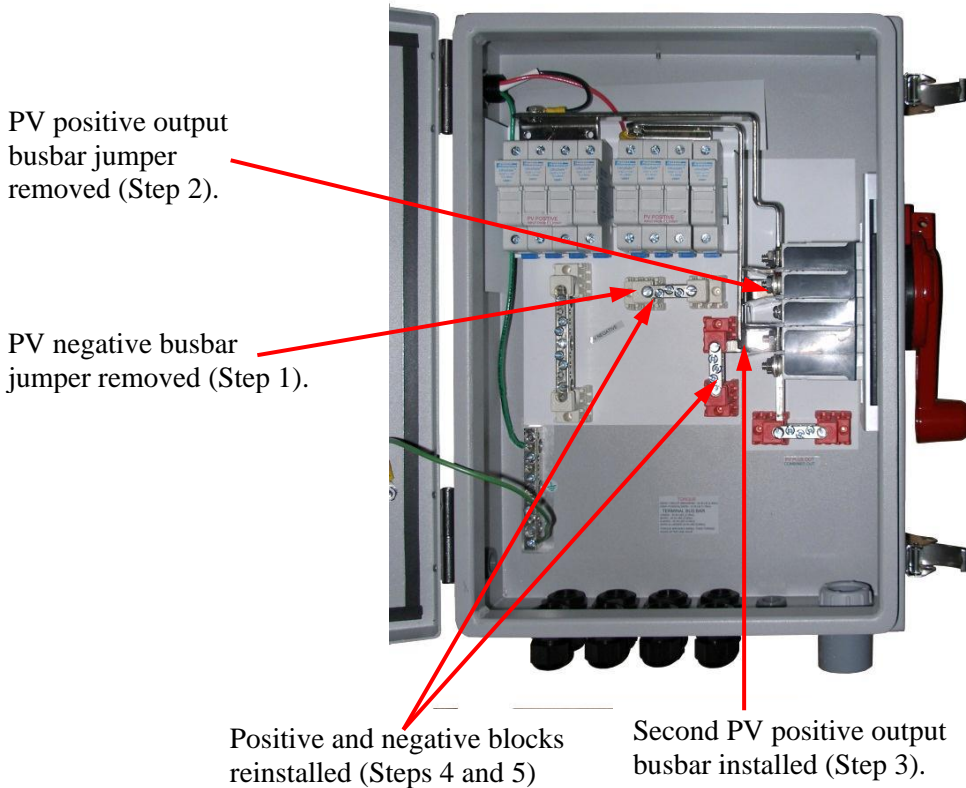

PV positive output busbar jumper removed (Step 2).

PV negative busbar jumper removed (Step 1).

Positive and negative blocks reinstalled (Steps 4 and 5)

Second PV positive output busbar installed (Step 3).

When finishing the conversion, compare your result with the photo (Left) to be sure that all steps were completed correctly. You should now have two separate four string combiners in one box. This example has one MNSPD. Refer to the wiring diagrams beginning on Page 17 for adding a second MNSPD (sold separately).

Left over parts should include the PV negative busbar jumper removed in Step 1, the PV positive busbar removed in Step 2, and the PV negative Non-Isolated busbar jumper.

MNPV8HV Configured for 2 -Inverters

MNPV8HV (cont)

Reconfiguring Parallel to Non-Isolated:

NOTE: The MNPV8HV TYPE 4X is shown, but the process is the same for the MNPV8HV TYPE 3R.

Step 1: Remove output blocks and negative jumper busbar

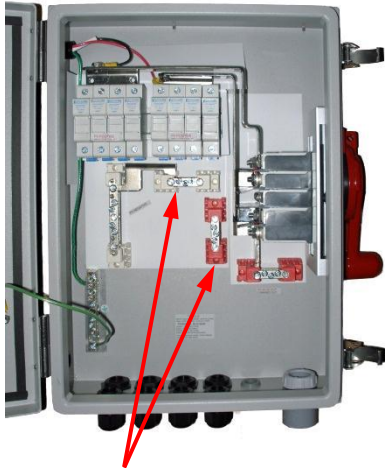

Remove positive and negative blocks and set aside. This is to provide access for the next steps.

Step 2: Remove positive output busbar

Replace only this nut at this time

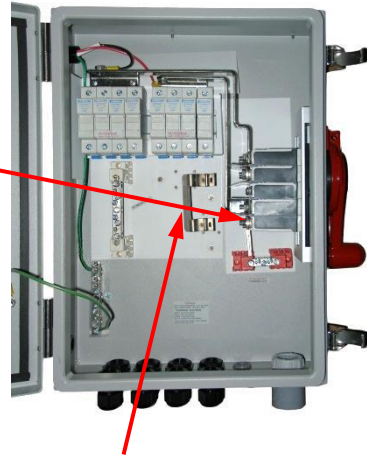

Remove positive jumper busbar from switch, set aside, it is not used in this configuration. Replace nut on lowest position only

Step 3: Install negative output busbar

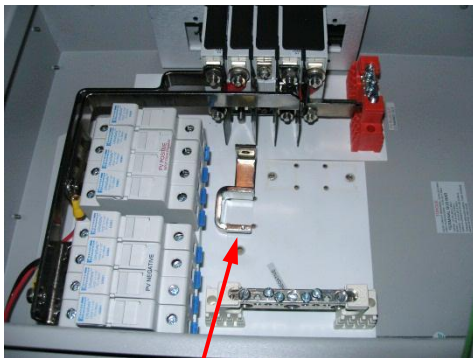

Install busbar on switch as shown.

Step 3 (cont): Install negative output busbar

Replace PV Positive sticker with PV Negative sticker. This location only

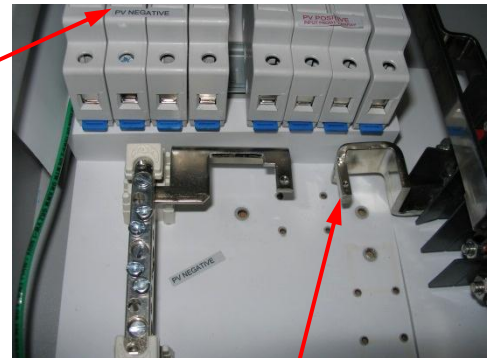

Busbar shown installed

MNPV8HV (cont)

Step 4: Reinstall negative block

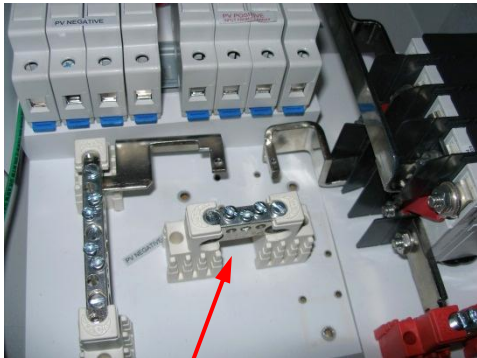

Install negative out block with screws removed in Step 1. Tighten onto busbars. Refer to torque chart on Page 5.

Step 5: Reinstall block

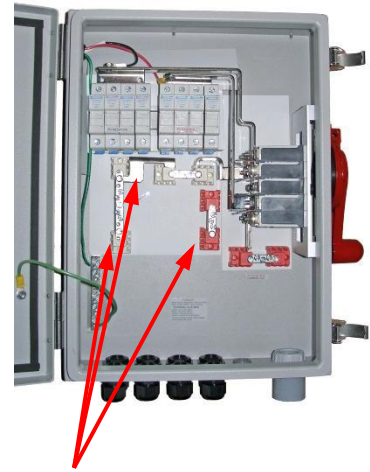

These terminal blocks are not used in this configuration. If desired you may remove them and use elsewhere, otherwise you may leave them installed here. Be sure to seal any holes left open.

Install PV negative output busbar (Step 3).

PV positive label changed to PV negative label (Step 3).

PV positive output busbar jumper removed (Step 2).

PV positive terminal block / negative block and busbar – are not used in this configuration. They are installed here to maintain watertightness. they may be removed if the mounting holes are sealed.

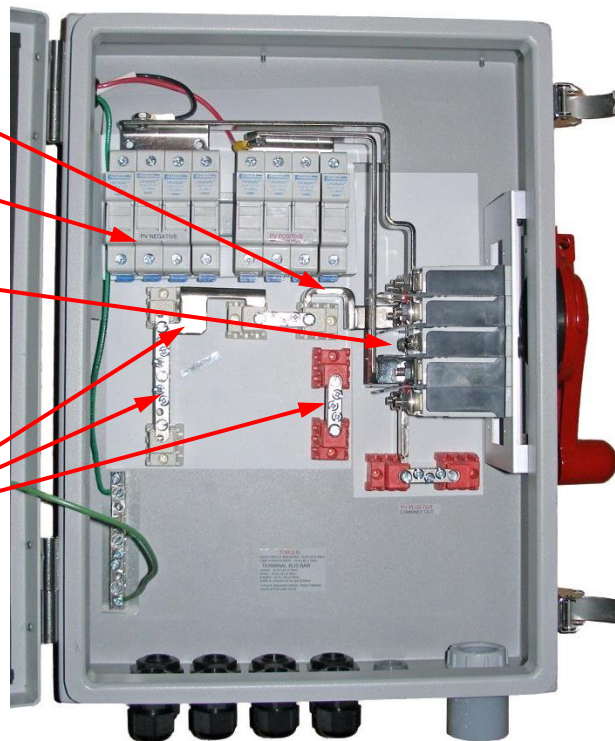

When finished, compare your result with the photo (Left) to be sure that all steps were completed correctly. You should now have a combiner ready for four Non-Isolated inputs (Fuses on each Positive and Negative string input with disconnects on positive and negative combined outputs).

Leftover parts should include the PV positive output busbar jumper removed in Step 2, and the PV negative output busbar removed in Step 3.

MNPV8HV Configured as Non-Isolated

MNPV4HV and MNPV6HV Combiners



MNPV4HV TYPE 3R Deluxe

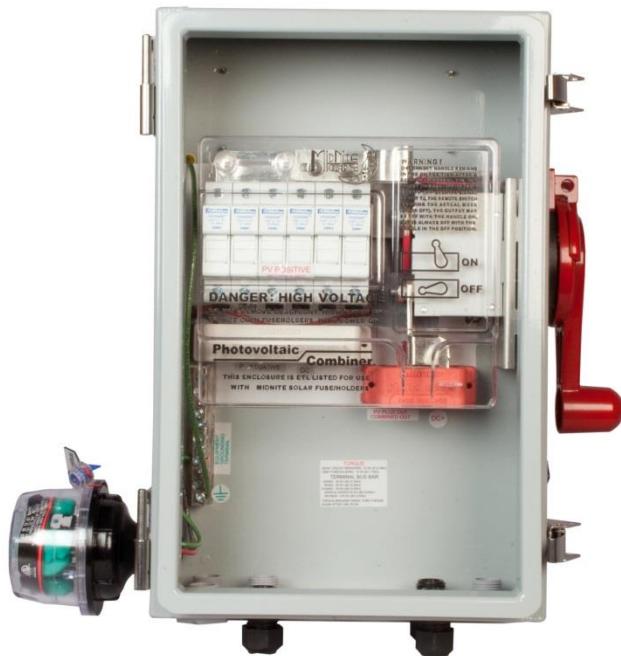

MNPV6HV TYPE 4X

MNPV4HV TYPE 3R Basic, MNPV4HV TYPE 3R Deluxe, and MNPV6HV TYPE 4X Combiners are shipped configured as 4- or 6-string combiners and are not field reconfigurable.

MNPV4HV Disco 3R - Basic Disconnecting Combiner has 80A busbars, 100A switch, and has two poles in series to make a 600V switch. Refer to MNPV6HV wiring diagram on Page 23.

MNPV4HV Disco 3R - Deluxe Disconnecting Combiner has 80A busbars, 100A switch with a third pole which is the feedback micro switch for the birdhouse system shutdown. It also includes one MNSPD600. Refer to MNPV6HV wiring diagram on Page 23.

MNPV6HV Disco 4X PV Disconnecting Combiner, 3 poles, 125A busbars, 100A switch with feedback for the birdhouse and accepts the optional power supply.

MNPVHV8-DLTL and MNPVHV16-DLTL Combiners

The MNPVHV8-DLTL and MNPVHV16-DLTL Combiners are available in NEMA 3R and NEMA 4X models. They are split into two sections each with separate positive and negative for each section. These combiners are fully compatible with the MidNite Solar Rapid Shutdown System.

The MNPV8HV-DLTL allows you to take 4 strings in and combine them into 2 strings out. Strings 1 and 2 go to channel A out and Strings 3 and 4 go to channel B, allowing for two MPPT channels out to a transformerless inverter.

The MNPV16HV-DLTL allows you to take 8 strings in and combine them into 2 strings out. Strings 1,2,3 and 4 go to channel A out and Strings 5,6,7 and 8 go to channel B, allowing for two MPPT channels out to a transformerless inverter.

2 isolated 600v strings for a 2 channel inverter

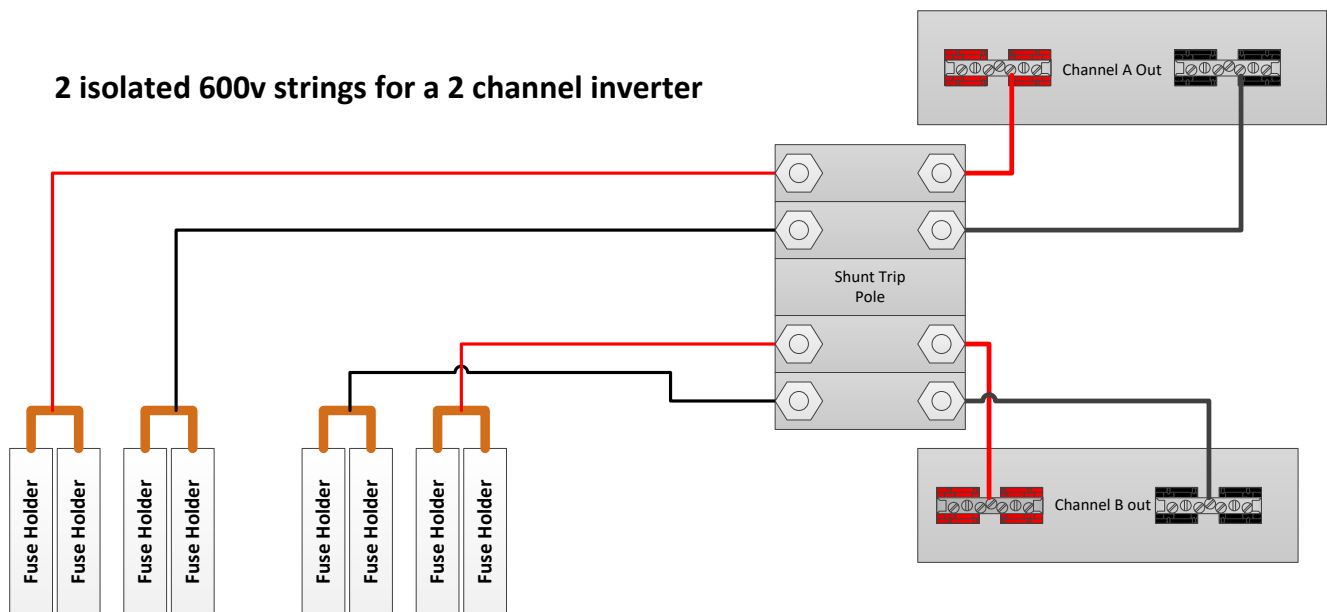

4 isolated 600v strings for a 2 channel inverter

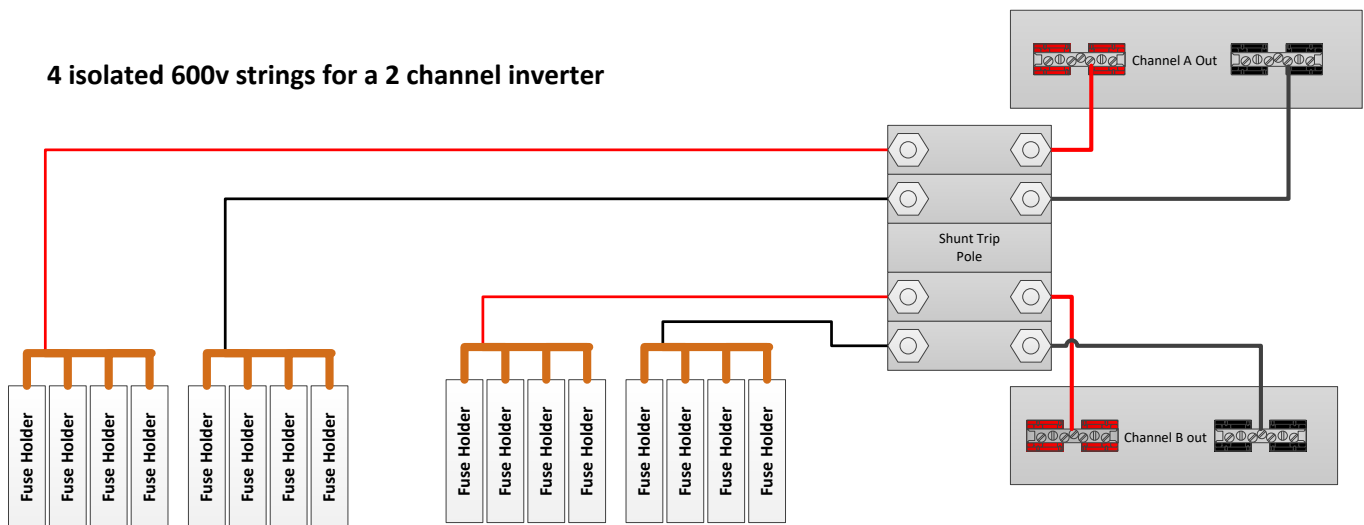

Installing MNSPD

The MNPVHV Combiner comes with one MNSPD to protect against surges. A second MNSPD (sold separately) can be added to protect 2-inverter configurations. Refer to the wiring diagrams starting on Page 17.



MNSPD Surge Protector Device

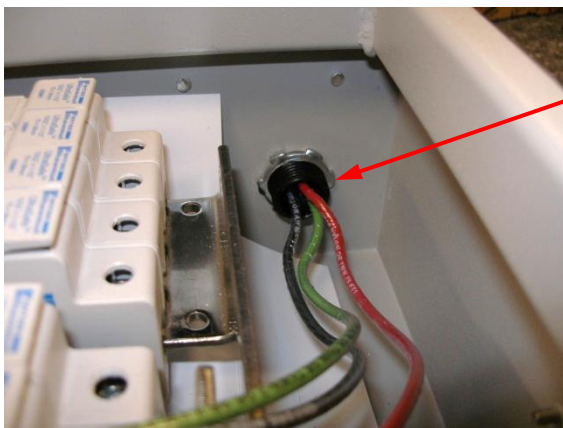

Remove the hole plug from the side of the combiner. Remove the nut from the MNSPD. Pull the wires through the side of the combiner and secure with the supplied nut. Insure that the silicone washer is installed on the outside of the chassis to maintain watertightness.

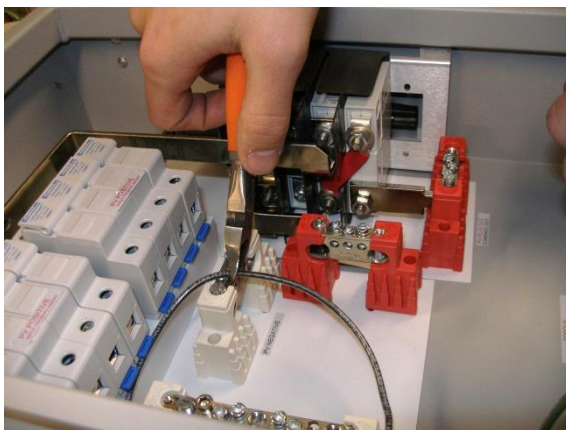

The wiring varies based on which configuration is used, so the wires will need to be cut to length. Refer to the wiring diagrams beginning on Page 17 for details on your configuration

In this example (2 Inverters) the black wire is run to the negative and cut to length, stripped and secured in in the negative busbar. Add a length of white heatshrink to the end of this wire to signify the grounded conductor. The red connects to the combined PV Plus busbar, the green wire goes to the ground terminal block. The second MNSPD (sold separately) connects in the same way to the other PV positive and negative busbars with the green connected to the ground terminal block.

MNPVHV Disco Instructions (continued)

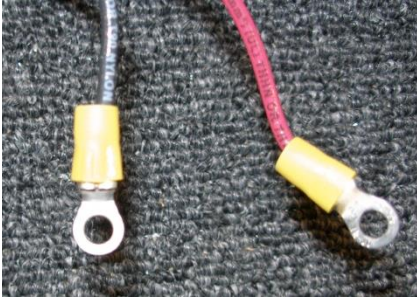

Ring lugs are included to allow easy installation of the MNSPD. If they are to be used, then you would need to strip the wire, push it into the barrel of the ring lug and crimp the barrel with an appropriate crimper. Make sure to pull on the wire after crimping to verify that the crimp is adequate.

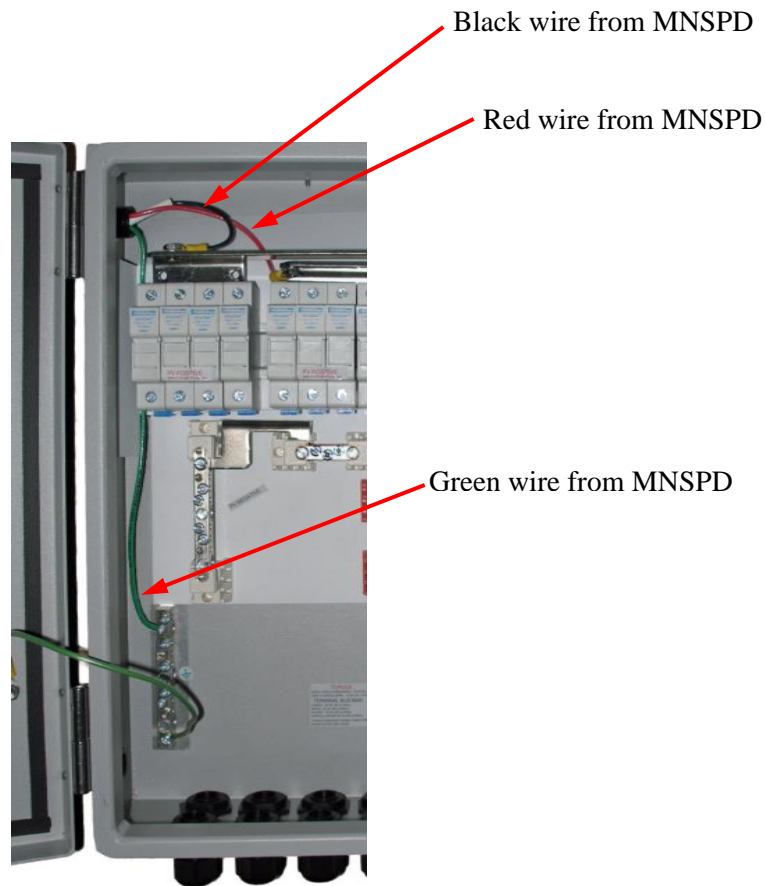

Connections for Non-Isolated

Refer to the wiring diagrams starting on Page 17 for more information or if adding a second MNSPD600 (not included).

Wiring

The MNPVHV Combiners can be configured to meet the combining and disconnecting needs of a wide array of solar system setups. All Combiners are shipped from the factory configured as parallel. Below are the various wiring diagrams.

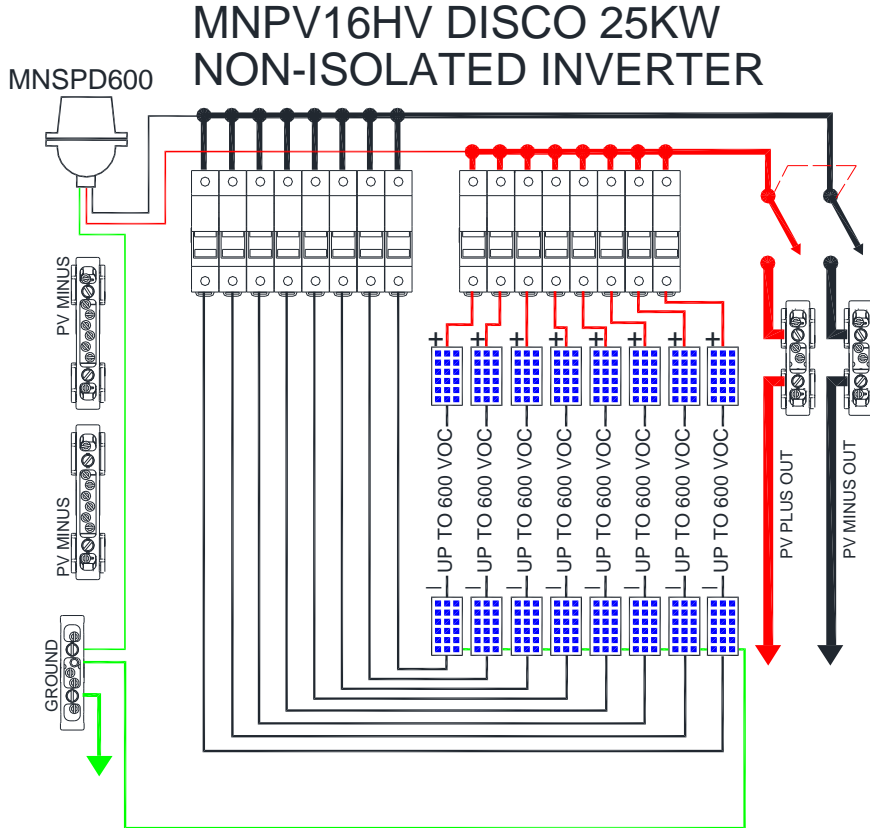

Here the Combiner is set up as two separate eight string combiners. One section combining the positive side of the strings and the other combining the negative side. Both sides are disconnected at the same time.

PV MINUS terminal blocks are Not Used in this configuration

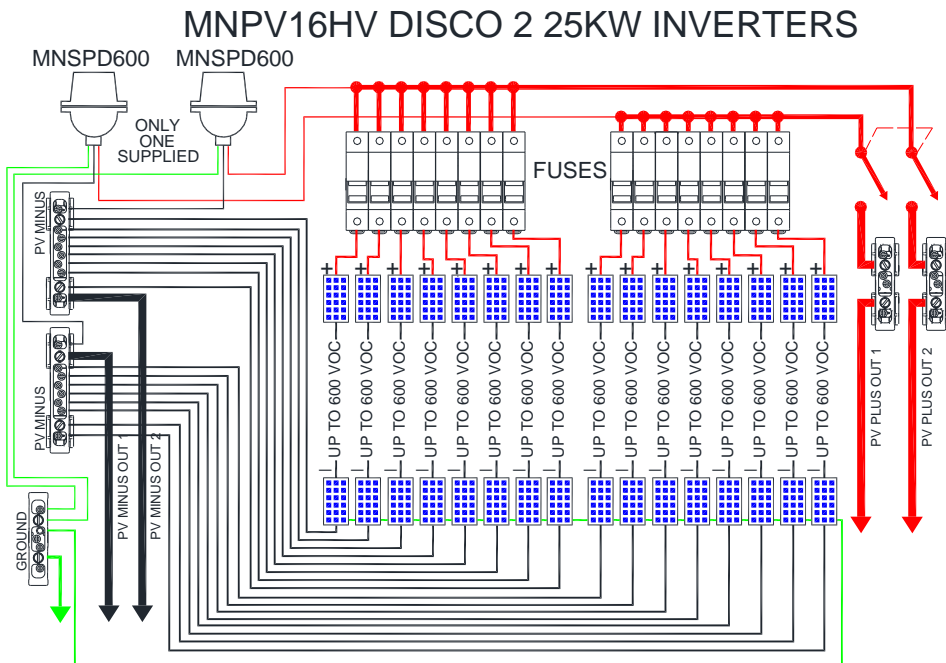

This arrangement allows the 16-position combiner to act as two separate 8-position combiners that disconnect together. Note that the second MNSPD600 is sold separately.

MNPV16HV DISCO-PARALLEL 50KW INVERTER

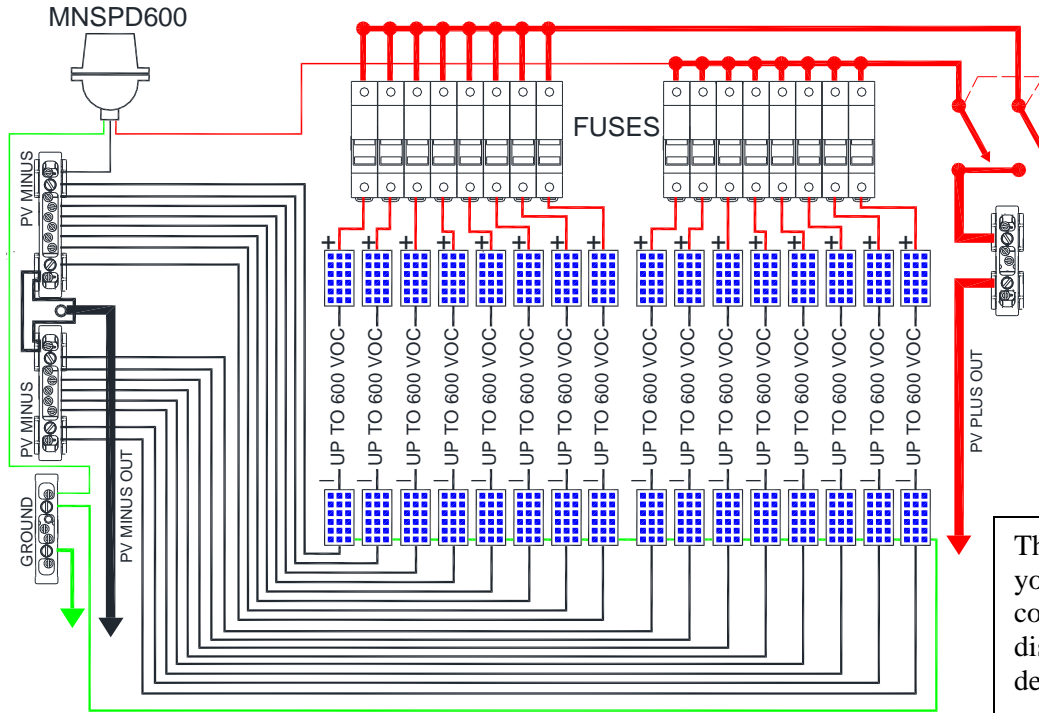

The parallel setup gives you a single 16-position combiner with disconnect. This is the default configuration.

MNPV8HV DISCO NON-ISOLATED INVERTER

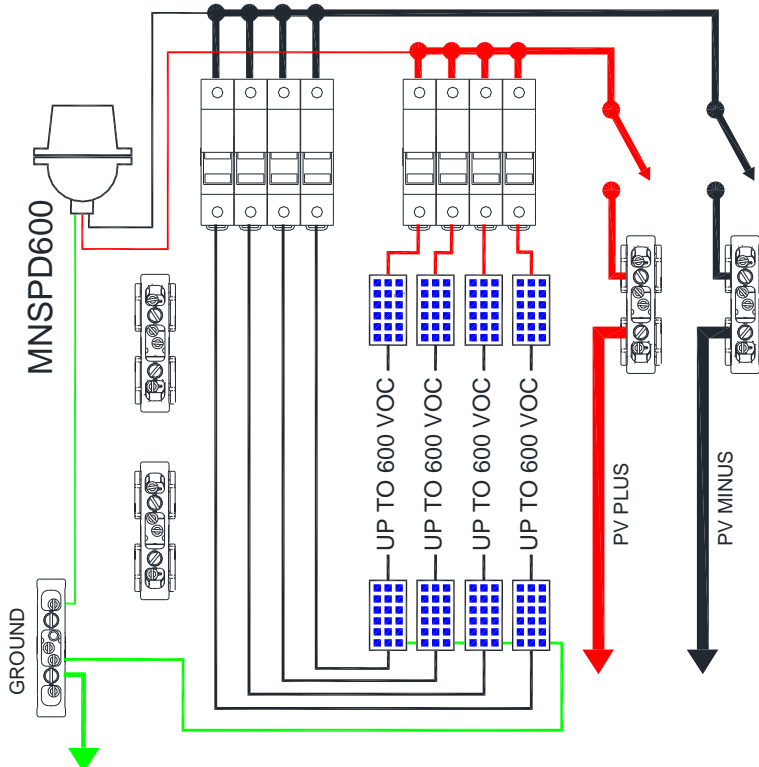

Here the Combiner is set up as two separate, 4-string combiners. One section combining the positive side of the strings and the other combining the negative side. Both sides are disconnected at the same time.

MNPV8HV DISCO 2 INVERTERS

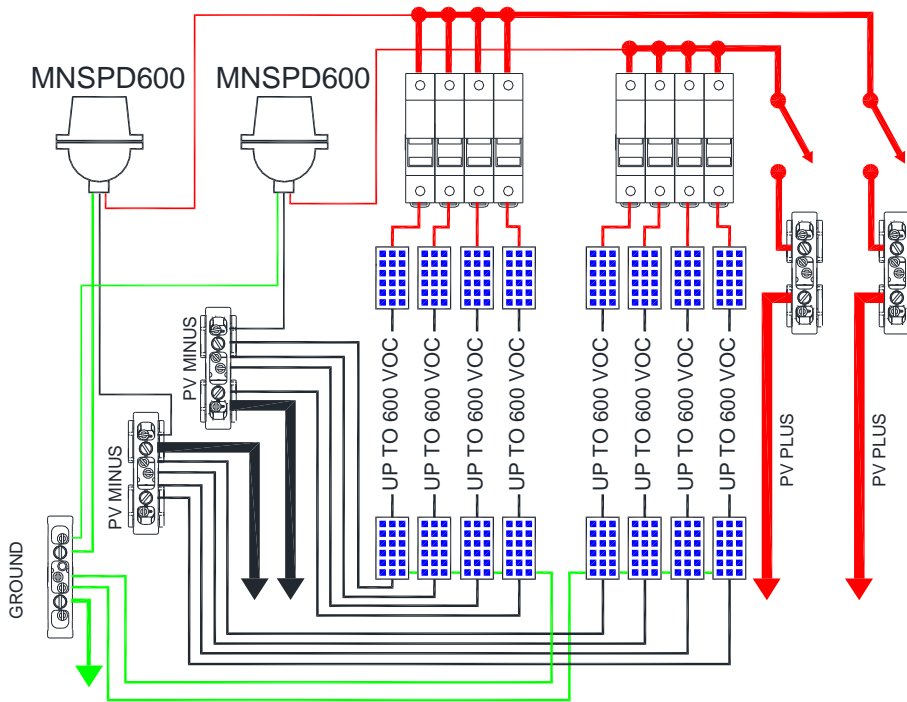

This arrangement allows the 8-position combiner to act as two separate, 4-position Combiners that disconnect together. Note that the second MNSPD600 is sold separately.

MNPV8HV DISCO-PARALLEL

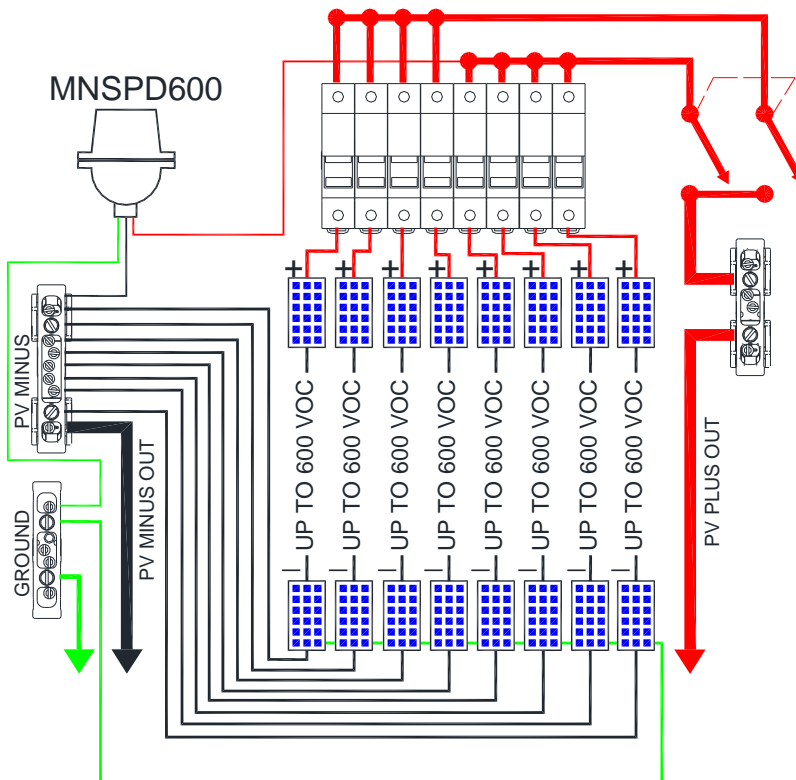

The parallel setup gives you a single 8-position Combiner with disconnect. This is the default configuration.

MNPV6HV DISCO

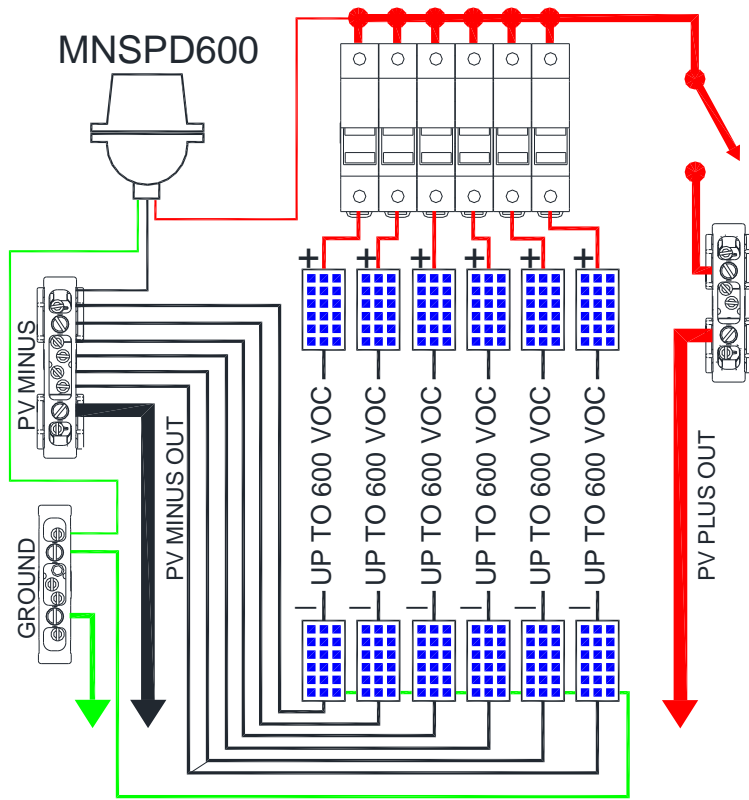

This is the typical wiring for the MNPV6HV Disconnecting Combiner. The MNPV4HV is wired the same but with 4 strings.



All Midnite Solar products are assembled under the watchful eye of Midnite the cat.

Optional Accessories



MNBIRDHOUSE

- Located at ground level, the Birdhouse provides a safe means to disconnect high voltage PV arrays from MidNite Disconnecting Combiners
- Hard-wired connection gives positive feedback that the Disconnect on the roof has actually been thrown. Connection is via 600V or 1000V Cat 5 USE-2 cable
- Up to four separate means of power including battery backup insures that the disconnect will be tripped when the button is pushed
- Voice and LEDs confirm level of safety (day or night) to the person pushing the button
- NEMA 3R UV resistant enclosure
- Able to disconnect multiple PV Disco Combiners
- Firefighter approved
- 600V Cat 5 USE-2 90° cable available from Midnite Solar



When using the Birdhouse with any of the DISCO combiners, you must also add the MNDISCOPSB Power Supply Board.

Installing the MNDISCOPSB

You will need:

3/16" Slotted screwdriver
#1 Phillips screwdriver

Wire strippers
¼" Nutdriver

Wire crimper (to attach lugs)

Included in the MNDISCOPSB Kit:



Qty	Description	MidNite Solar PN
1	MNDISCOPSB	8-037-10
1	Formex Insulator	5-144-1
2 Ft	Wire #18 AWG Red	9-367-1
2	Pin Terminal #18-22 AWG	6-668-1
2	Screw #6-32	6-060-1
2	Standoff ½ Inch	6-154-1
1	Silicone Grease Packet	9-757-1
2	#6 Internal Tooth Washer	6-155-1
2	Circuit Board Support	6-148-1

Installing the MNDISCOPSB (cont)

Step 1: Remove the top cover and deadfront (Page 3).



Step 2: Place the Formex insulator as shown.



Step 3: Install metal standoffs (2) and plastic PCB supports (2).



Note: Circuit board is shown without non-removable clear cover.

Step 4: Set board in place as shown.



Step 5: Secure board with 6-32 screws (2).

Loosen wire bundle from switch
Trim wires to 5" and strip 1/4"



Step 6: Connect the two black wires to the left side of the terminal block marked "BK1" and "BK2."

Connect the two red wires to the right side of the terminal block marked "S1" and "S2."

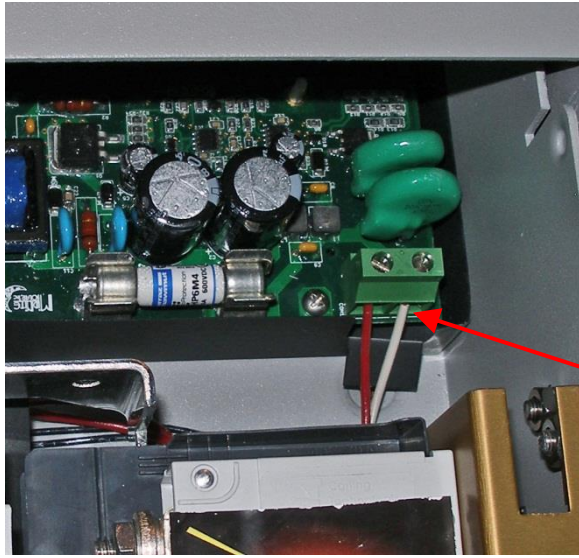

Step 7a: Strip one end on the red and white wires included in the kit ¼” and connect them as shown with the red wire on the left side of the terminal block marked “PV+” and the white wire on the right side marked “PV-.” Route the wires downward under the large switch.

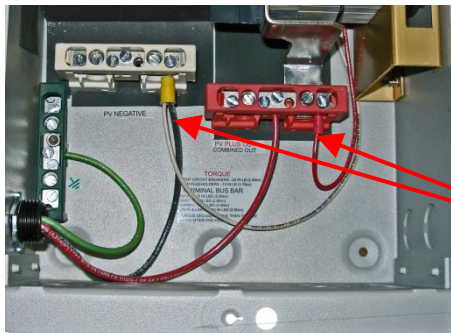

Step 7b: Strip the other end of the red and white wire about ¼”. Install the red wire into a red ferrule and crimp, then install into the red terminal block. Put the white wire along with the black wire from the MNSPD into the ferrule and crimp.

If no MNSPD is installed, the white wire must be crimped into a red ferrule also and then into the white terminal block.



Ferrule

MNPVHV Disco Instructions (continued)

Step 8: Installing the included MNSPD Surge Protector with the MNDISCOPSB.

First, select the mounting location for the MNSPD. There are several knockouts located on the sides and bottom that can be used for this. Remove the desired knockout, pull the MNSPD wires through and secure with the supplied nut.



MNSPD Shown installed in left side knockout.

Crimp one of the small red terminals on the red wire from the circuit board terminal block. Be sure to make a strong secure connection. The purpose of this terminal is to allow the #18 AWG wire to be held securely into the terminal strip.

The white wire from the circuit board terminal block may be crimped into the yellow terminal along with the black wire from the MNSPD or it may be crimped by itself into the second red terminal.

Step 9: Verify your work then replace deadfront and top cover.



MNPVHV4 TYPE 3R Shown wired with MNDISCOPSB and MNSPD surge protector

MNPVHV Disco Instructions (continued)

MNPV4HV TYPE 3R, INCLUDED/REPLACEMENT PARTS: MIDNITE SOLAR PART NUMBER

1 EACH DEADFRONT	5-101-1
4 EACH LOCKNUT ½ INCH	6-092-1
4 EACH FUSES,	9-084-1
4 EACH STRAIN RELIEF	9-458-2

MNPV6HV TYPE 4X, INCLUDED/REPLACEMENT PARTS: MIDNITE SOLAR PART NUMBER

6 EACH BLACK TWO WIRE STRAIN RELIEFS,	9-458-2
10 EACH ½ INCH NUTS,	5-147-1
SURGE PROTECTION DEVICE	MNSPD 600V
6 EACH FUSES,	9-084-1
DEADFRONT	5-120-1
HOLE PLUG	5-146-1
WASHER	5-149-1

MNPV8HV TYPE 3R, INCLUDED/REPLACEMENT PARTS: MIDNITE SOLAR PART NUMBER

8 EACH BLACK TWO WIRE STRAIN RELIEFS,	9-458-2
8 EACH ½ INCH NUTS,	9-458-2
SURGE PROTECTION DEVICE	MNSPD 600V
BUSBAR, NEGATIVE OUT	3-272-1
BUSBAR, NEGATIVE / POSITIVE OUT	3-315-1
8 EACH FUSES,	9-084-1
DEADFRONT	5-112-1

MNPV8HV TYPE 4X, INCLUDED/REPLACEMENT PARTS: MIDNITE SOLAR PART NUMBER

8 EACH BLACK TWO WIRE STRAIN RELIEFS,	9-458-2
14 EACH ½ INCH NUTS,	5-147-1
SURGE PROTECTION DEVICE	MNSPD 600V
BUSBAR, NEGATIVE OUT	3-272-1
BUSBAR, NEGATIVE / POSITIVE OUT	3-315-1
8 EACH ½" NPT STRAIGHT HOLE PLUG	5-146-1
8 EACH FUSES,	9-084-1
DEADFRONT	5-112-1

MNPV16HV TYPE 4X, INCLUDED/REPLACEMENT PARTS: MIDNITE SOLAR PART NUMBER

16 STRAIN RELIEFS	9-458-2
28 EACH ½ INCH NUTS,	5-147-1
SURGE PROTECTION DEVICE	MNSPD 600V
BUSBAR,	3-295-1
BUSBAR, OUT 3	3-321-1
16 EACH FUSES,	9-084-1
DEADFRONT	5-125-1
HOLE PLUG	5-146-1
WASHER	5-149-1

MNPVHV DISCO Knock-out Locations

MNPV4HV

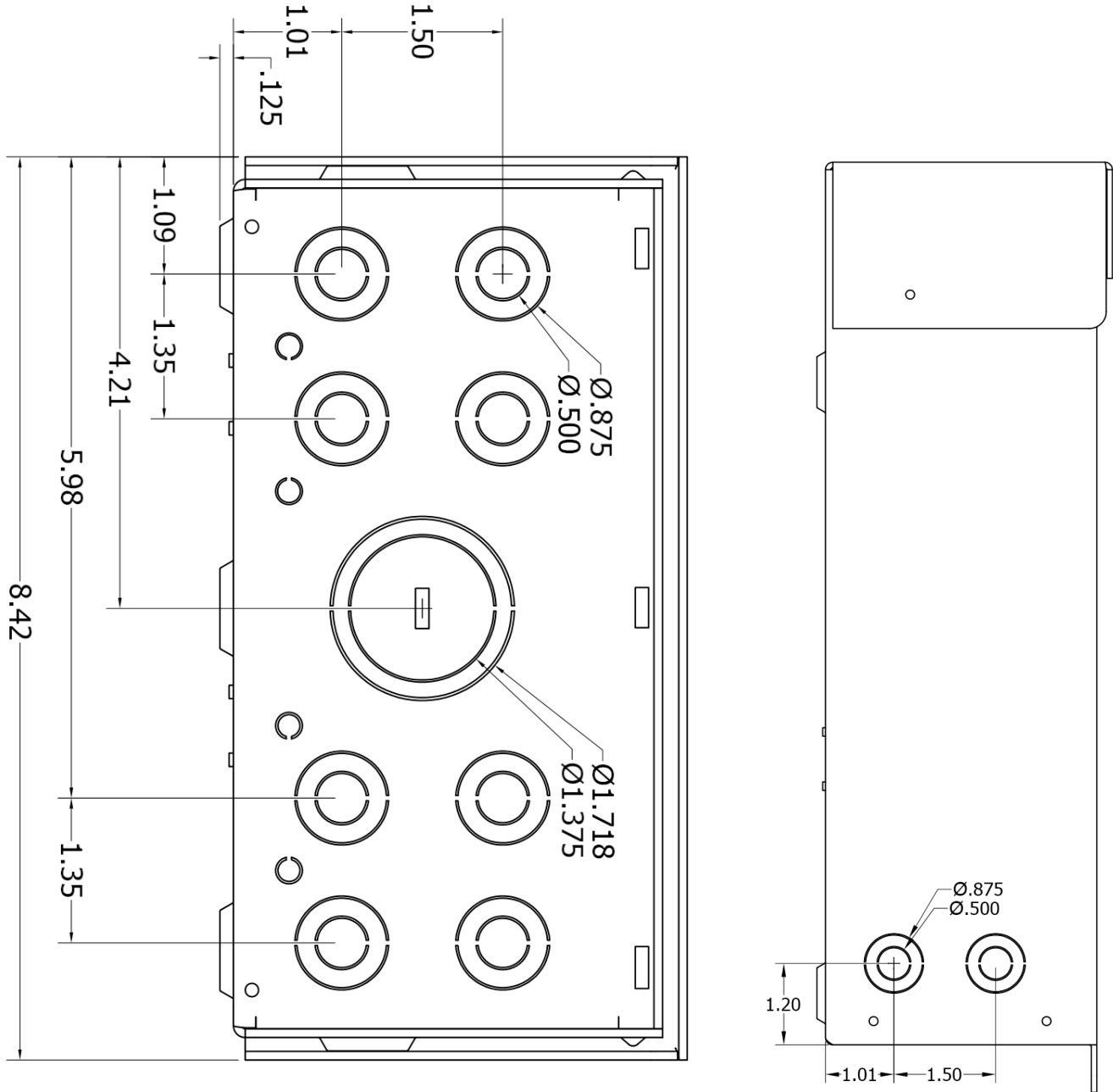

MNPV4HV bottom and side knockout location and size

MNPV6HV

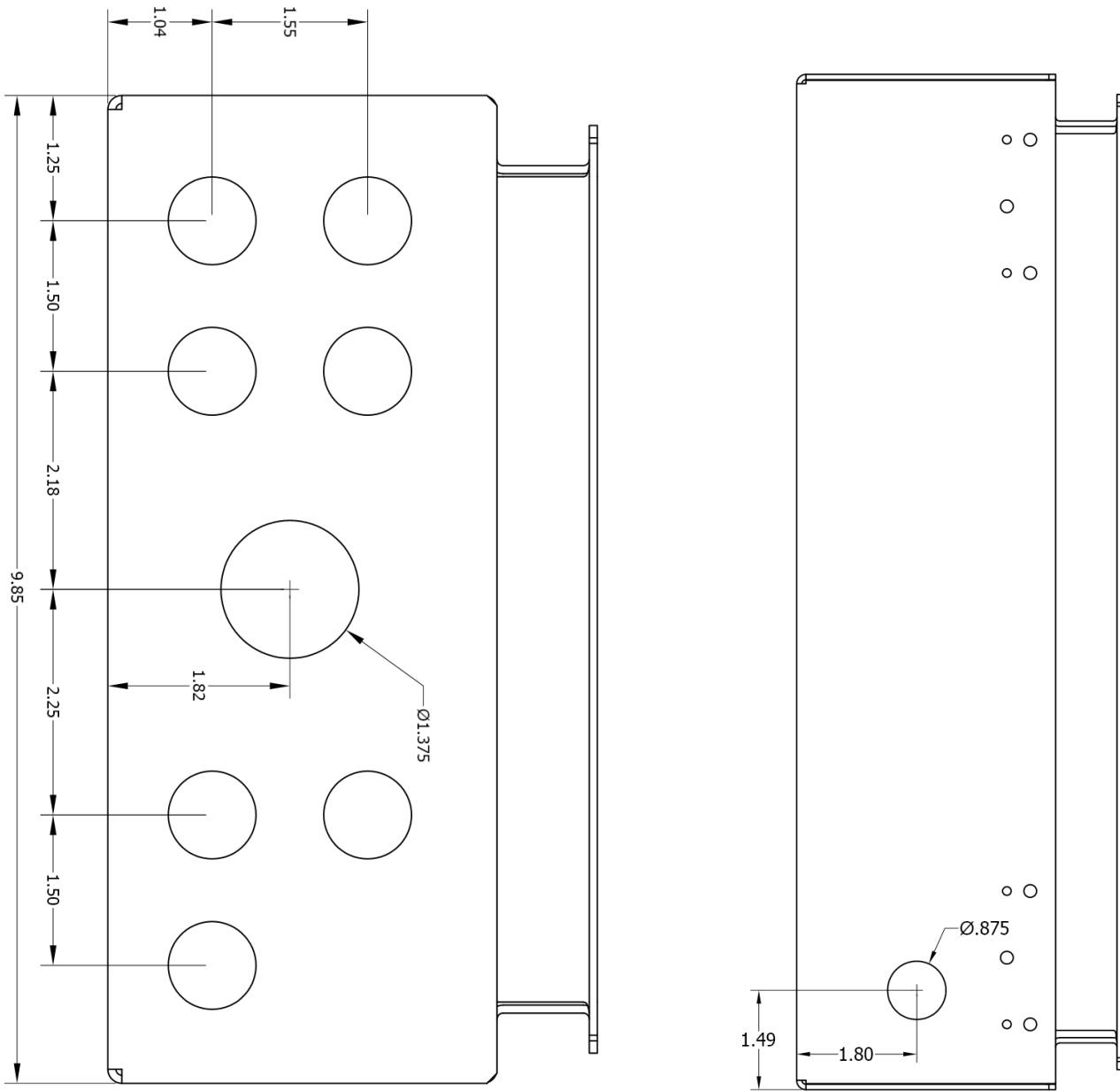

MNPV6HV bottom and side knockout location and size

MNPV8HV

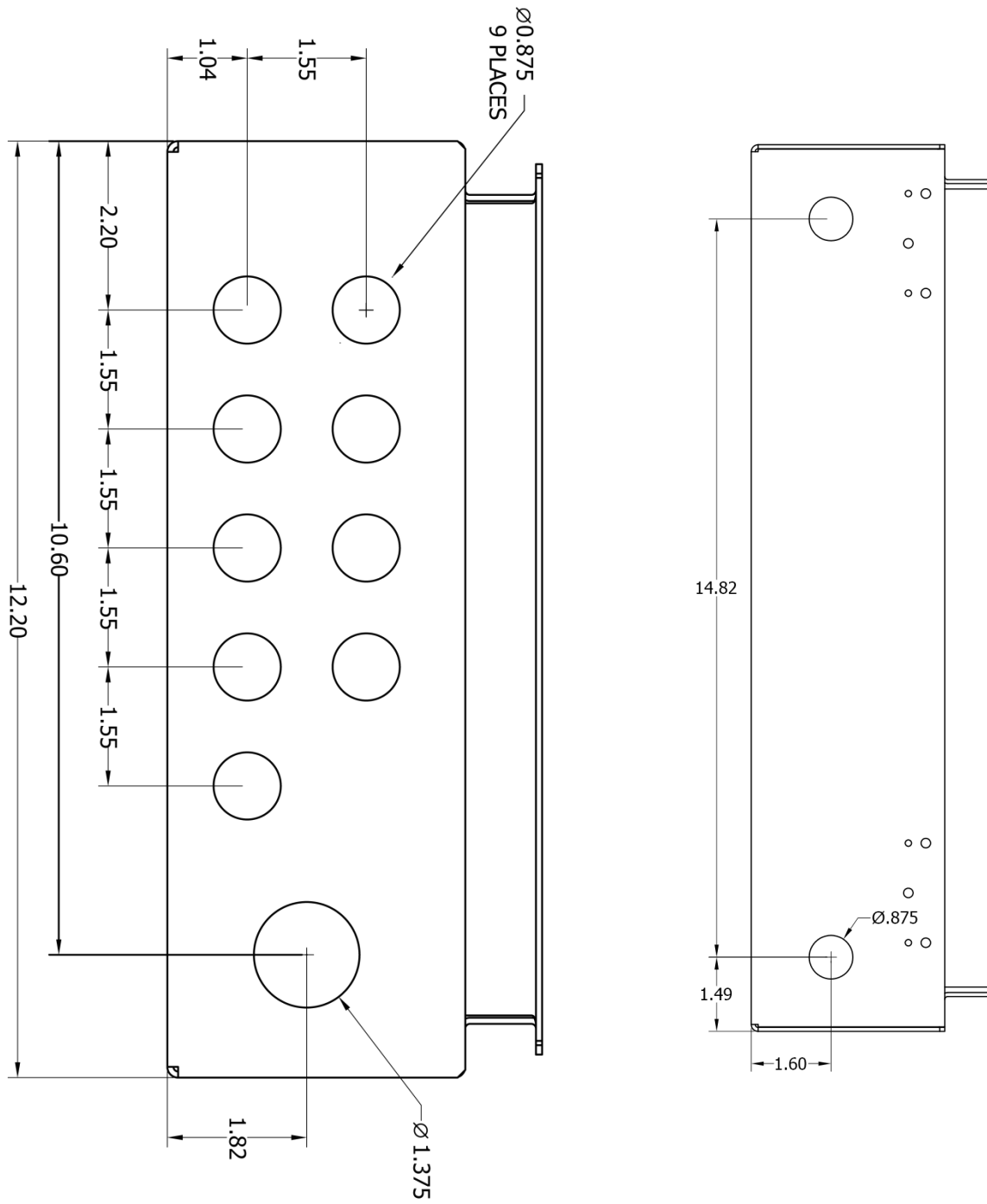

MNPV8HV Type 4X bottom and side knockout location and size

MNPV8HV

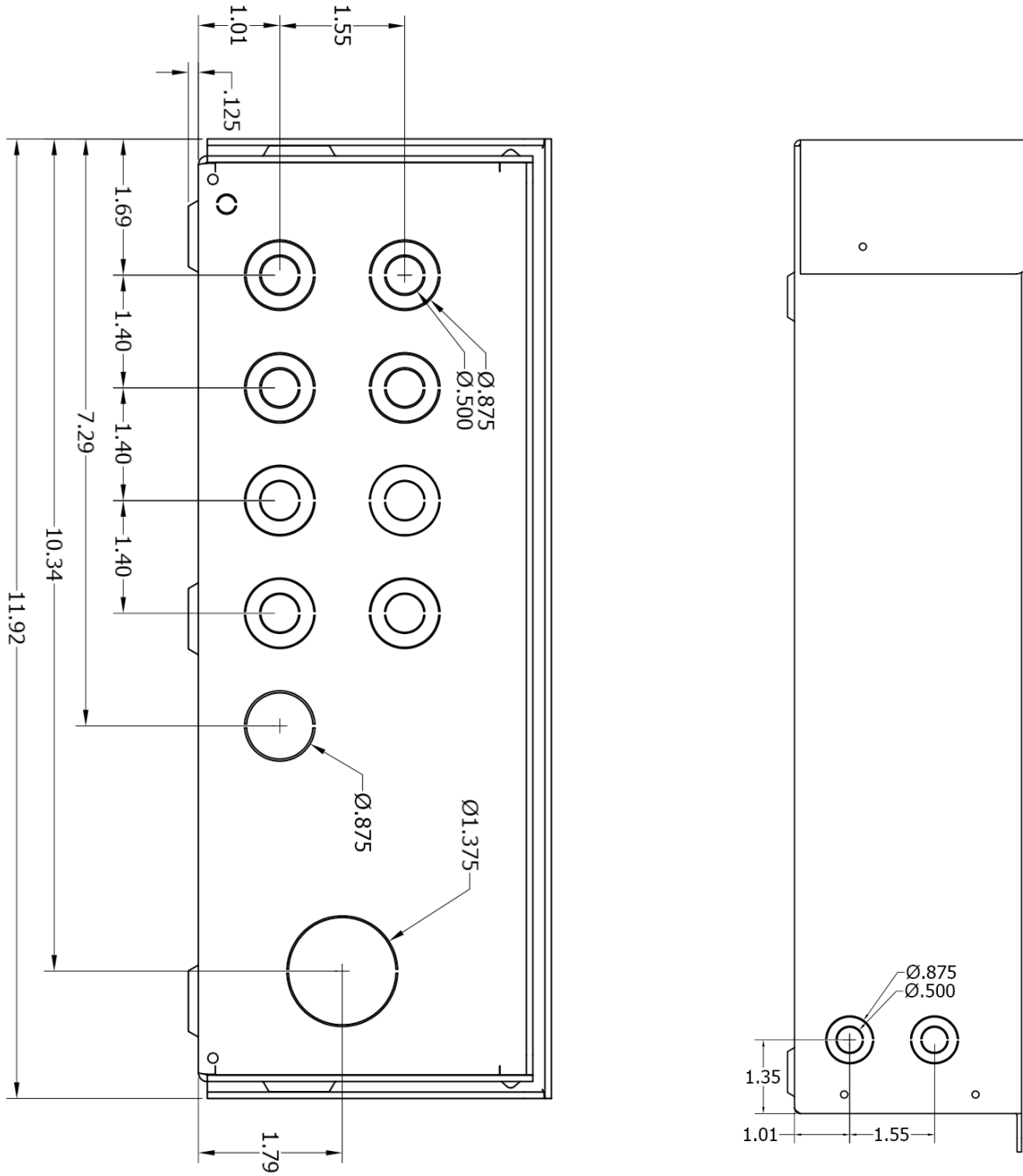

MNPV8HV Type 3R bottom and side knockout location and size

MNPV16HV

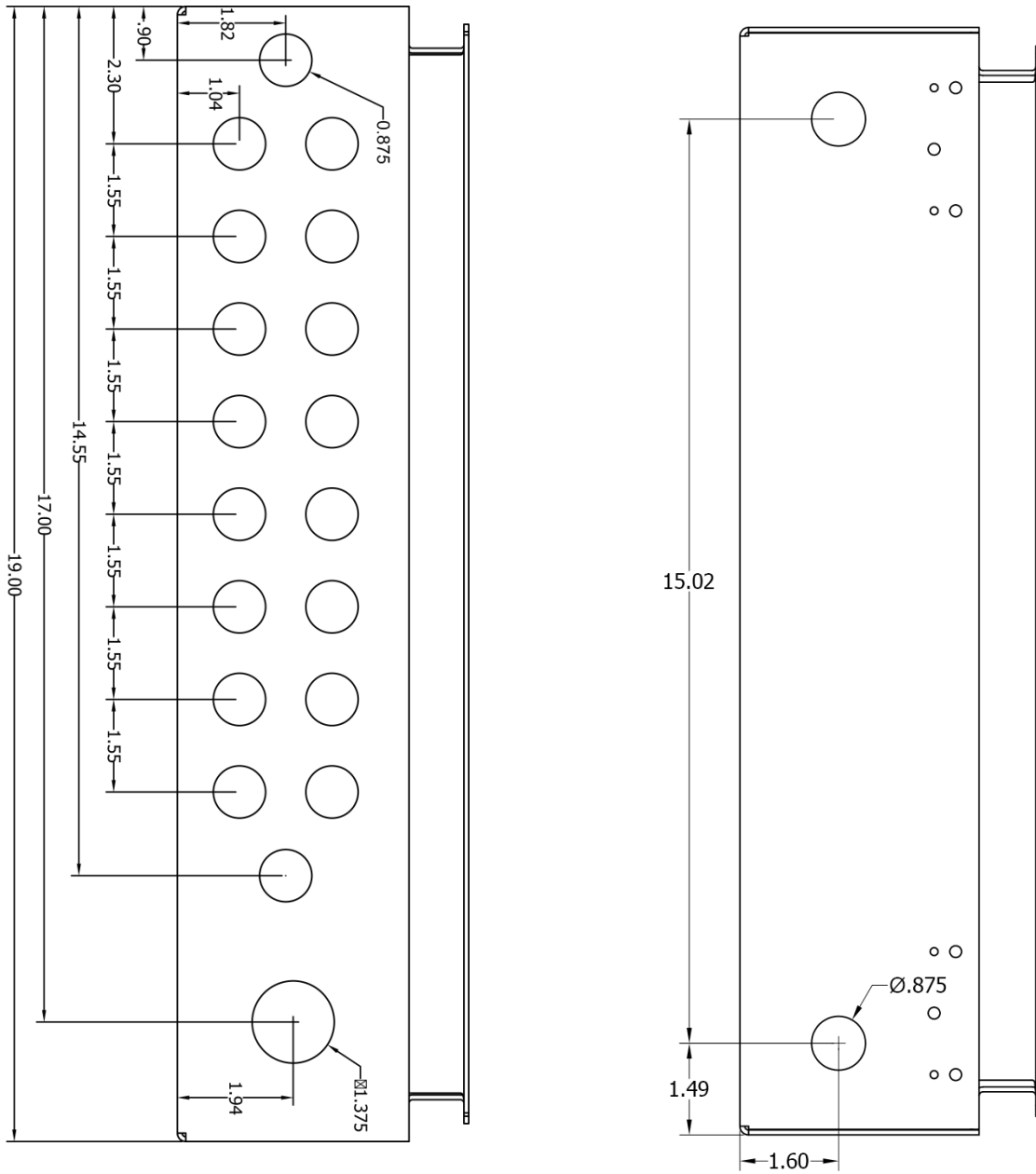

MNPV16HV bottom and side knockout location and size

MIDNITE SOLAR INC. LIMITED WARRANTY

MidNite Solar Power electronics, sheet metal enclosures and accessories

MidNite Solar Inc. warrants to the original customer that its products shall be free from defects in materials and workmanship. This warranty will be valid for a period of five (5) years for all products except the MNBRAT Charge Controller along with the MNBIRDHOUSE batteries, these will be two (2) years. MidNite Solar will not warranty third-party inverter components used in MidNites pre-wired systems. Those components are warranted by the original manufacturer.

MidNite Solar offers an extended warranty for all the Classic MPPT charge controllers. Six months prior to the end of the warranty period customers can ship their Classic back to MidNite Solar with a check for \$147 dollars plus shipping and we will replace any wearable parts and do a general tune-up. This will extend the warranty by 2 additional years.

At its option, MidNite Solar will repair or replace at no charge any MidNite product that proves to be defective within such warranty period. This warranty shall not apply if the MidNite Solar product has been damaged by unreasonable use, accident, negligence, service or modification by anyone other than MidNite Solar, or by any other causes unrelated to materials and workmanship. The original consumer purchaser must retain original purchase receipt for proof of purchase as a condition precedent to warranty coverage. To receive in-warranty service, the defective product must be received no later than two (2) weeks after the end of the warranty period. The product must be accompanied by proof of purchase and Return Material Authorization (RMA) number issued by MidNite Solar. For an RMA number contact MidNite Solar Inc., 19115 62nd Ave NE, Arlington, WA 98223 (360) 403-7207. Purchasers must prepay all delivery costs or shipping charges to return any defective MidNite Solar product under this warranty policy. Except for the warranty that the products are made in accordance with, the specifications therefore supplied or agreed to by customer:

MIDNITE SOLAR MAKES NO WARRANTY EXPRESSED OR IMPLIED, AND ANY IMPLIED WARRANTY OF MERCHANTABILITY OR FITNESS FOR A PARTICULAR PURPOSE WHICH EXCEEDS THE FOREGOING WARRANTY IS HEREBY DISCLAIMED BY MIDNITE SOLAR AND EXCLUDED FROM ANY AGREEMENT MADE BY ACCEPTANCE OF ANY ORDER PURSUANT TO THIS QUOTATION. MIDNITE SOLAR WILL NOT BE LIABLE FOR ANY CONSEQUENTIAL DAMAGES, LOSS OR EXPENSE ARISING IN CONNECTION WITH THE USE OF OR THE INABILITY TO USE ITS GOODS FOR ANY PURPOSE WHATSOEVER. MIDNITE SOLAR'S MAXIMUM LIABILITY SHALL NOT IN ANY CASE EXCEED THE CONTRACT PRICE FOR THE GOODS CLAIMED TO BE DEFECTIVE OR UNSUITABLE.

Products will be considered accepted by customer unless written notice to the contrary is given to MidNite Solar within ten (10) days of such delivery to customer. MIDNITE SOLAR is not responsible for loss or damage to products owned by customer and located on MIDNITE SOLAR'S premises caused by fire or other casualties beyond MIDNITE SOLAR's control. This warranty is in lieu of all other warranties expressed or implied.

MIDNITE SOLAR INC.
19115 62nd AVE NE
ARLINGTON, WA 98223

Email: info@midnitesolar.com
PH: 360-403-7207