

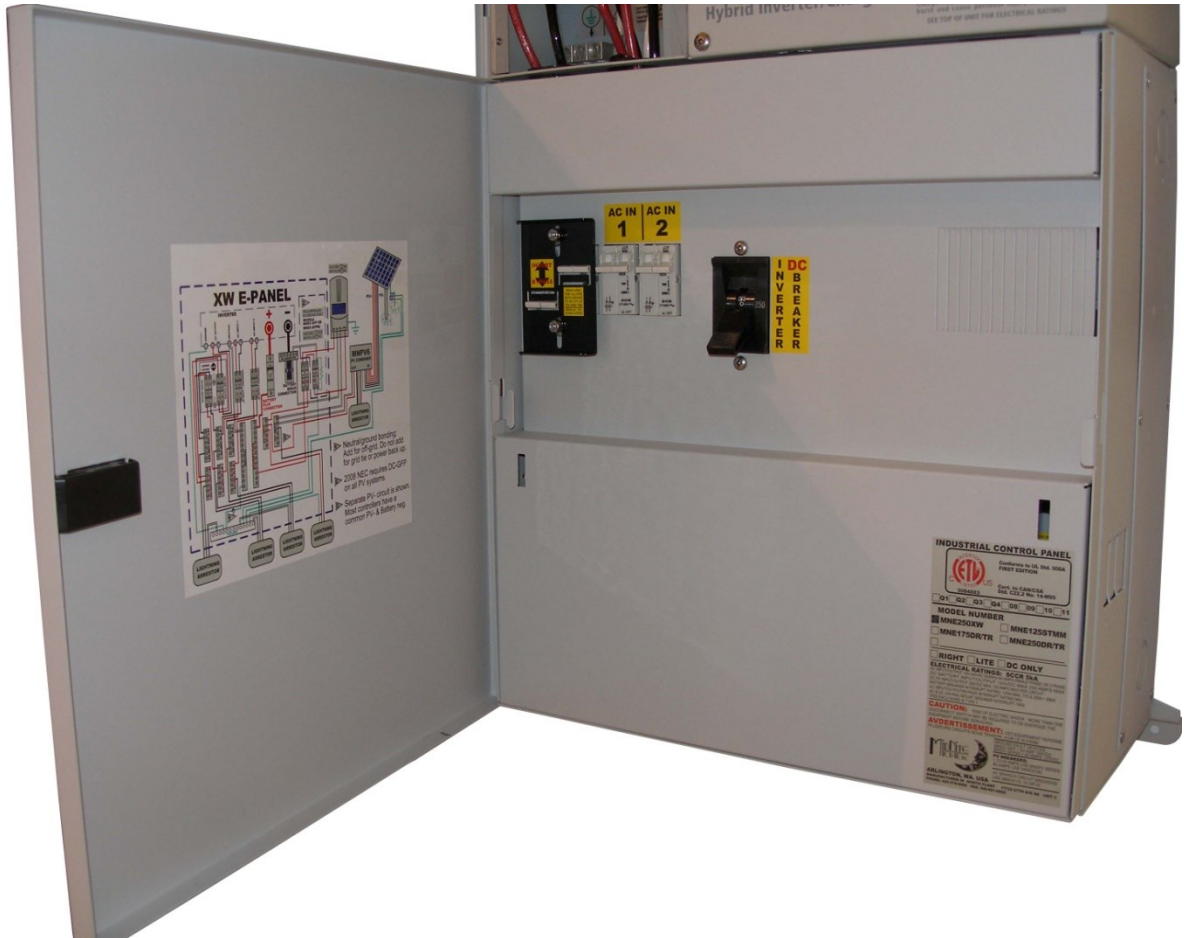

XW E-Panel Instructions



Model MNE250XW

The MidNite Solar XW E-Panel is designed for a single XW inverter installation. Use this installation manual to aid in installation. The installation of an electrical system such as this fall under the guidelines of the NEC in the USA. Canadian electrical codes have jurisdiction in Canada. These instructions are not intended to be used in lieu of these local and federal codes, but rather are used as specific to this product. You may need to consult with a professional Solar installer or electrical inspector when in doubt on code specific questions and system installation issues. Even though the E-Panel incorporates and simplifies numerous separate electrical circuits into one enclosure, an inverter system such as this is still a very sophisticated and somewhat complicated electrical system.

IMPORTANT SAFETY INSTRUCTIONS

SAVE THESE INSTRUCTIONS - These instructions contain important safety and operating instructions for MidNite Solar E-Panels.

If you do not fully understand any of the concepts, terminology, or hazards outlined in these instructions, please refer installation to a qualified dealer, electrician or installer. These instructions are not meant to be a complete explanation of a renewable energy system.

GENERAL PRECAUTIONS

WORKING WITH OR IN THE VICINITY OF A LEAD ACID BATTERY, SEALED OR VENTED IS DANGEROUS. VENTED BATTERIES GENERATE EXPLOSIVE GASES DURING NORMAL OPERATION. FOR THIS REASON, IT IS VERY IMPORTANT THAT BEFORE SERVICING EQUIPMENT IN THE VICINITY OF LEAD-ACID BATTERIES YOU REVIEW AND FOLLOW THESE INSTRUCTIONS CAREFULLY.

If service or repair should become necessary, contact MidNite Solar Inc. Improper servicing may result in a risk of shock, fire or explosion. To reduce these risks, disconnect all wiring before attempting any maintenance or cleaning. Turning off the inverter will not reduce these risks. Solar modules produce power when exposed to light. When it is not possible to disconnect the power coming from the Photovoltaics by an external means such as a combiner, cover the modules with an opaque material before servicing any connected equipment.

Never attempt to charge a frozen battery.

When it is necessary to remove a battery, make sure that the battery bank disconnect breaker is in the off position and that the PV breakers, grid breakers and any other sources of power to the inverter are in the off position. Then remove the negative terminal from the battery first.

To reduce risk of battery explosion follow these instructions and those published by the battery manufacturer as well as the manufacturer of any additional equipment used in the vicinity of the batteries. Before installing the battery enclosure, read all instructions and cautionary markings in or on any connected electrical equipment.

Avoid producing sparks in the vicinity of the batteries when using vented batteries. Provide ventilation to clear the area of explosive gases. Sealed AGM and Gel batteries do not under normal conditions create explosive gases. Be especially cautious when using metal tools. Dropping a metal tool onto batteries can short circuit them. The resulting spark can lead to personal injury or damage to the equipment. Provide ventilation to outdoors from the battery compartment when installing vented batteries such as golf cart T-105 batteries. The addition of a spill tray is also a good idea.

Clean all battery terminals. Very high currents are drawn from the batteries; even a small amount of electrical resistance can result in overheating, poor performance, premature failure or even fire.

Have plenty of fresh water and soap nearby in case battery acid contacts skin, clothing or eyes. Wear complete eye and clothing protection. Always avoid touching eyes while working near batteries. If battery acid or battery terminal corrosion contacts skin or clothing, wash immediately with soap and water. If acid enters the eyes, immediately flood with cool running water for at least 15 minutes and get medical attention immediately. Baking soda neutralizes battery acid electrolyte. Keep a supply near the batteries.

Do not work alone. Someone should be in the range of your voice or close enough to come to your aid when you work with or near electrical equipment.

Remove rings, bracelets, necklaces, watches etc. when working with batteries, photovoltaic modules or other electrical equipment. Power from an illuminated photovoltaic array makes a very effective arc welder with dire consequences if one of the welded pieces is on your person.

To reduce the risk of injury, connect only deep cycle lead acid type rechargeable batteries. Other types of batteries may leak or burst, causing personal injury or damage.

This equipment is NOT intended for use with life support equipment or other medical equipment or devices.

It is the responsibility of the installer to verify compliance with all applicable codes.

Before making any connections verify that the circuit breakers are in the off position including the inverter breaker. Double check all wiring before applying power.

XW E-Panel installation manual

Mounting The XW E-Panel:

The XW inverter should be mounted to the wall prior to installing the E-Panel. Pay attention to the total height of the system. Refer to the dimensioned drawing below.

Installing the E-Panel to the inverter: To install the E-Panel, remove the door and deadfront. Attach top and bottom wall mounting brackets to the E-Panel using four M6 x 10mm taptite screws supplied. The top mounting bracket slides up behind the inverter to space the inverter out the proper distance from the wall. The top mounting bracket does not screw to the wall, but rather just acts as a spacer

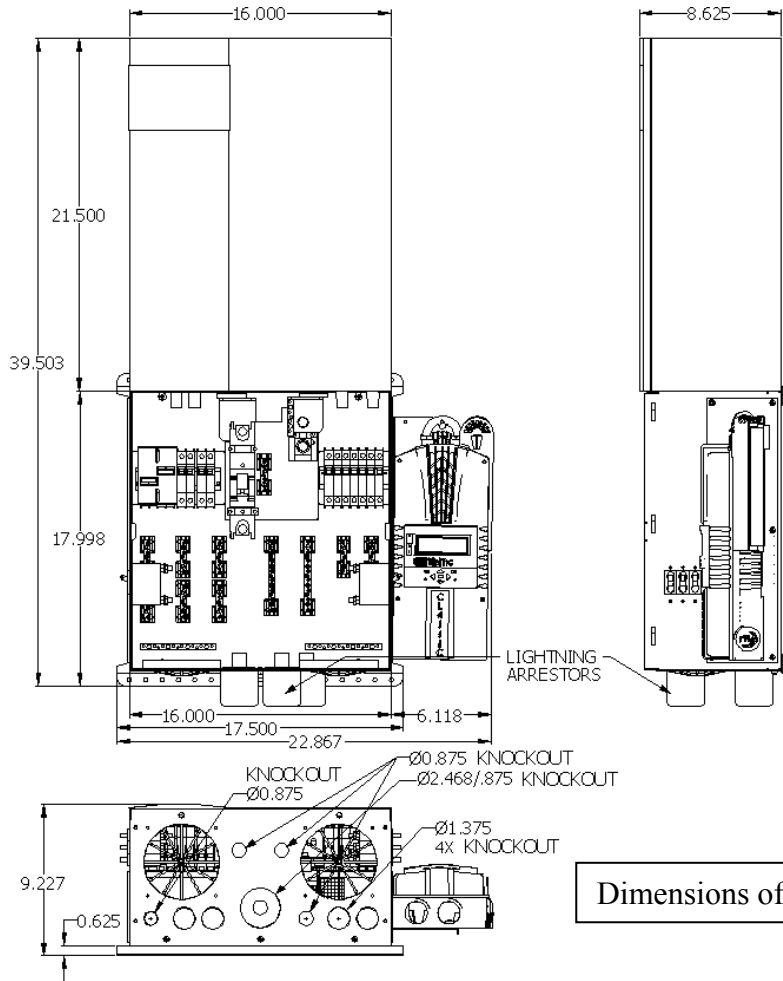

Mounting bracket dimensions.

Dimensions of XW E-Panel and inverter



Top left Top right Bottom left Bottom right
 Each mounting bracket is held on using two 6mm x 10mm thread forming screws.
 Use a #3 Philips screwdriver for these four screws.

XW E-Panel installation manual

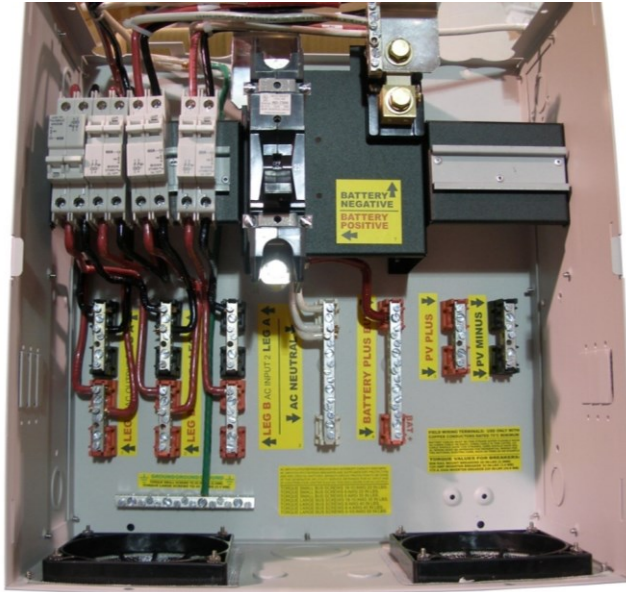

Main component placement

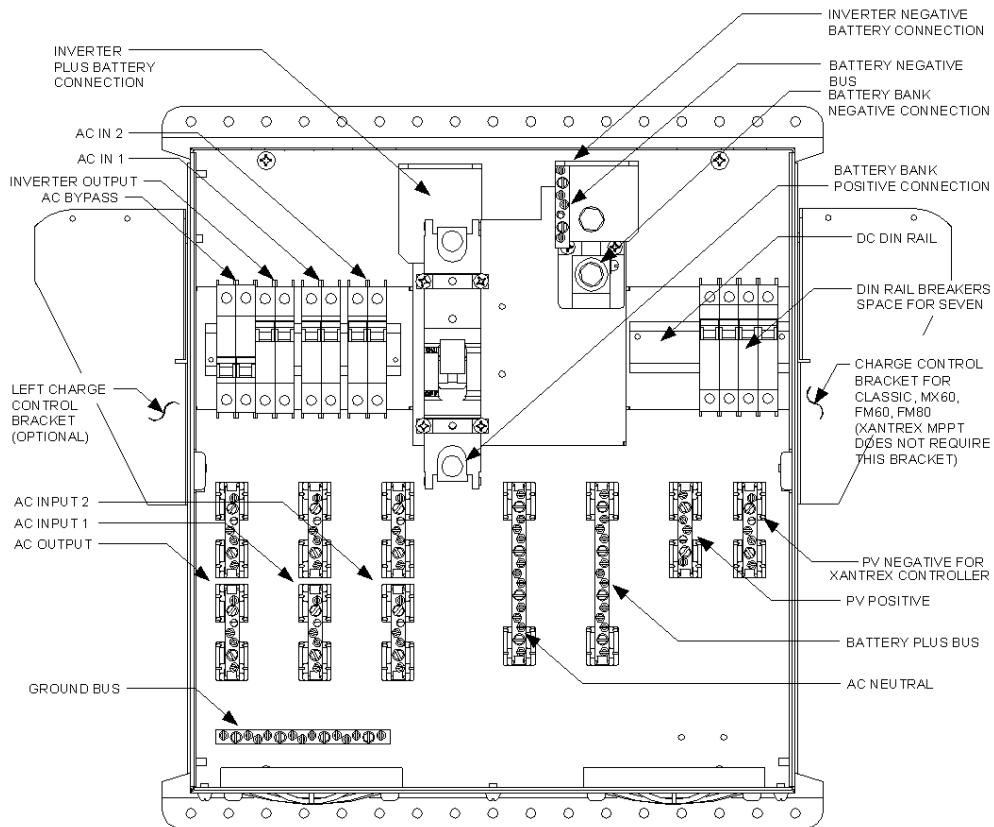

XW E-Panel installation manual

Installing the E-Panel to the inverter continued:

Remove two 5mm #2 Philips tip screws from the bottom of the inverter that will be used to attach the E-Panel. These two screws are the only attachment to the inverter. The bottom wall mounting bracket also needs to be secured to the wall. You must also remove the battery terminal bolts prior to setting the E-Panel in place. Note: 10-32 UNF screws are interchangeable with the 5mm screws if you should misplace them.

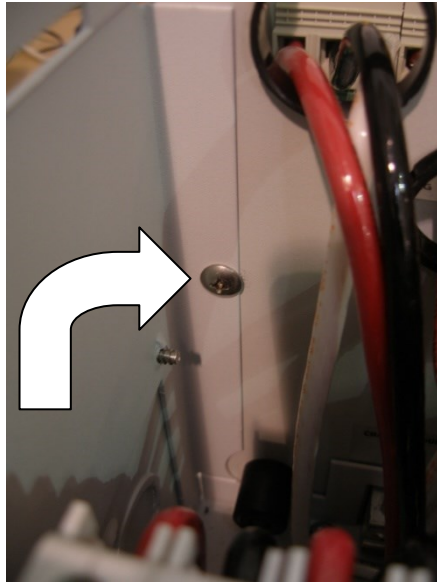

Left attachment. E-Panel to inverter

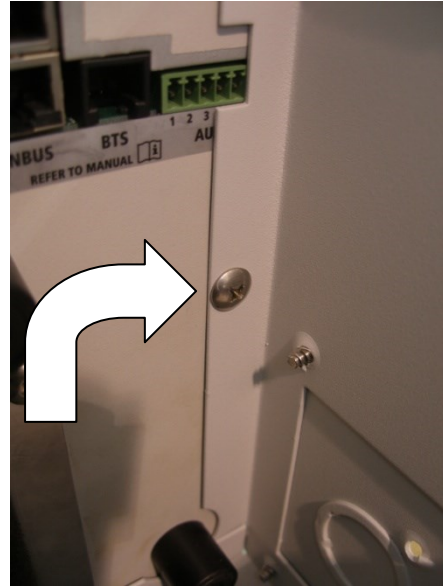

Right attachment. E-Panel to inverter

To gain access to these two main mounting screws, you will need a long #2 Philips screwdriver. The tip must be at least 9 inches long. Most tool boxes do not have a Philips screwdriver this long, so consider adding it to your arsenal of tools. Slide the AC breakers to the right a bit to allow the

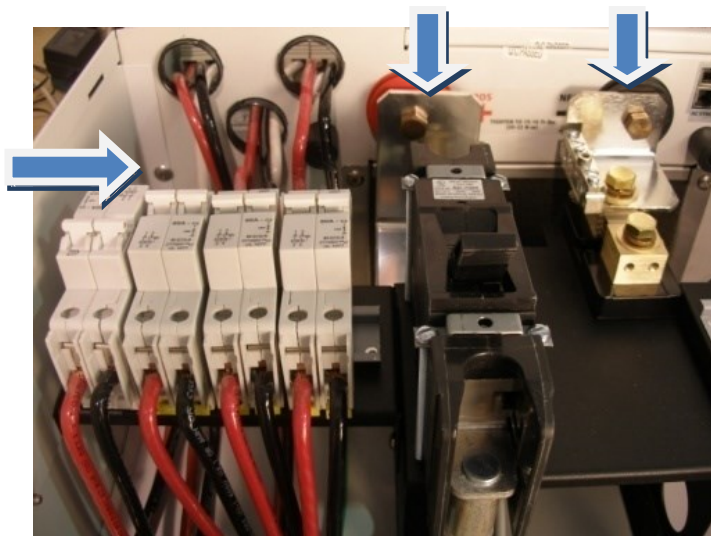

screwdriver to line up with the screw. Move them back after the E-Panel is secured to the inverter. Install the battery terminal bolts as shown to the left. Remove the left side plate of the E-Panel. This allows access to tighten the bottom of the battery plus bus bar located on the 250 amp circuit breaker. Both the Plus and Minus battery busbars are shipped loose for ease of alignment and must be tightened. Use a 9/16" wrench for these connections. (Note: some earlier bus bars may require enlarging the slot for battery terminals). If required, use a 3/8" drill and a strong pair of pliers to hold it while drilling.

XW E-Panel installation manual

Wiring: Start with the grounds. Wiring the system will be easier if grounds are done first.



Chassis ground connection to inverter

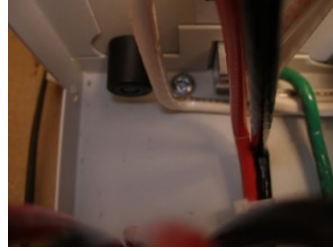

E-Panel earth ground bus (AC & DC)

The E-Panel comes with a 6AWG green ground wire shown above. The ground chassis lug on the bottom of the inverter is the same electrical connection as the three inside the wiring compartment of the inverter. You may use this large terminal as the one single ground connection to the inverter and then connect all other grounds to the E-Panel ground bus. Since the E-Panel ground, inverter chassis ground and wiring compartment grounds are all at the same potential, you may use any and all as required although electrical inspectors are used to finding all grounds on just one busbar. The E-Panel ground bus is the proper place for this single point ground on an off-grid system. Your main distribution panel ground is the proper AC ground for utility connected systems. Use the E-Panel ground bus for the DC grounds in a utility connected system. Inspectors will want to see a separate ground wire from AC and DC on a utility connected system. You can use a single ground wire from the E-Panel for AC and DC for an off-grid installation.

Neutral to ground bond: All AC electrical systems in North America must have an AC Neutral to Earth Ground bonding connection. A typical distribution panel such as Square D makes this bond by use of a bonding screw. That green screw grounds the neutral busbar when installed. Electrical inspectors are used to looking in the main distribution panel for this electrical bond. In a battery backed up grid tie or power back up installation, this bond has already been made in the main distribution / service entrance panel. Do not add it inside the E-Panel when the utility is connected. In an off-grid installation where there is no utility connection, the bond should be done inside the E-Panel as shown here.

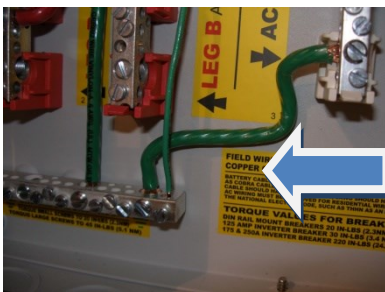

6AWG Neutral to Ground bonding wire. The bond should be done at the power source and since the E-Panel is central to the power generation, it is considered the source. Some electrical inspectors are used to looking for this bond to be accomplished in the distribution panel. They may ask you to move it to where they feel comfortable finding it. Don't fight it. The bond will work just fine in a Square D box too.

DC-GFP installation: The NEC 2008 requires a DC-GFP in all US systems!

When installing a DC-GFP in the PV circuit, make sure there is no battery minus to ground connection. That would effectively short out the sense circuit on the DC-GFP. MidNite solar has

XW E-Panel installation manual

two DC-GFP devices that fit the E-Panel. One is a 63 amp single circuit din rail mount device while the other is an 80 amp single circuit panel mount device. OutBack Power offers a two circuit 80 amp panel mount DC-GFP that also fits inside the E-Panel. The Xantrex DC-GFP's will not fit in the E-Panel. The MidNite Solar single circuit DC-GFP's are designed for a single PV array. Two MidNite DC-GFP's may be used to accommodate two arrays although the dual OutBack would for dual arrays and dual controllers cost less and take up less room. DC-GFP's are a very misunderstood device. When looking at a wiring diagram you will notice that part of the DC-GFP is a high current breaker. Connected in series with the GFP is yet another high current DC breaker. It is a common mistake to think the second breaker is unnecessary. NEC2008 requires a DC-GFP on all systems whether mounted on the roof top of a residence or not. The NEC also does not allow the DC-GFP to be the PV disconnect. When the DC-GFP is turned off, it leaves the battery negative ungrounded. The only time it is allowed that the system be ungrounded is during a fault condition. This requirement necessitates a PV disconnect in series with the DC-GFP.

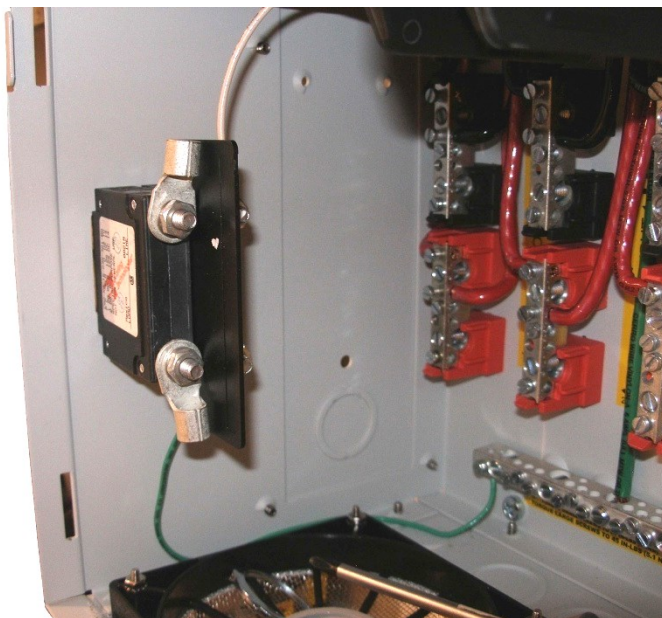
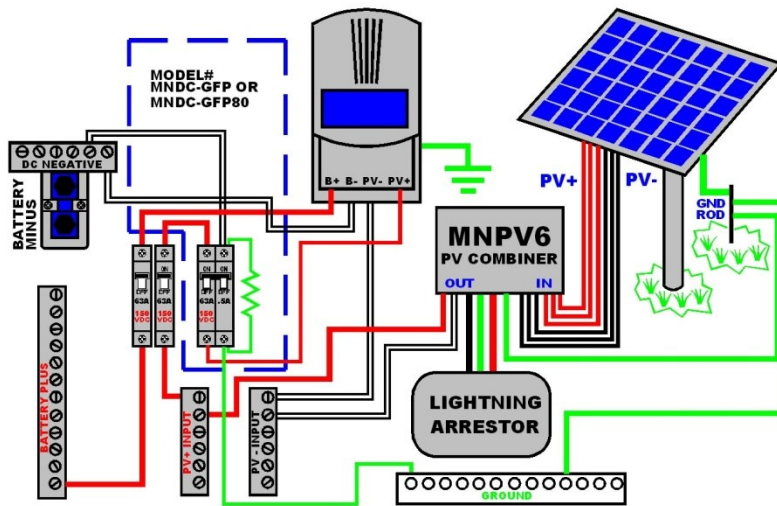

80 amp panel mount DC-GFP ready for the high current wires.



63 amp din rail DC-GFP wired with a 63 amp PV disconnect and a 63 amp controller output breaker.

XW E-Panel installation manual

The DC-GFP device monitors current flowing between battery negative and earth ground and will trip when more than ½ amp is present. There should be no current flowing in this circuit under normal circumstances. In the event your DC-GFP trips, it is usually on a new installation. One of two things is happening. 1: There is an actual ground fault in the wiring, or 2: there is an excess of current flowing through the large 63 or 80 amp breaker. The first thing an installer usually suspects in the case of this device tripping is that the device is faulty. Sorry, but this will not be the reason for a DC-GFP tripping, so **check your wiring!** Refer to the wiring diagram in these instructions or on the inside of the door. These wiring diagrams show a PV disconnect breaker connected directly after the PV array + busbar and before the DC-GFP. It doesn't matter which order these two devices are connected. The DC-GFP can be connected to the Array plus output before the PV disconnect just as well. Make sure the polarity of all DC breakers are correct. The din rail mount breakers have a + sign at the bottom terminal. Panel mount breakers have a "Line" marking on the top connection. The + and Line connections need to be connected to the most positive point in the circuit. Since the DC-GFP is acting as a switch and not as a breaker, the PV disconnect is the device that polarity needs to be observed. It is much easier to wire the din rail mount devices as shown in the picture, but the DC-GFP + connection is furthest away from the PV+ array. In the case of the panel mount 80 amp PV disconnect breaker and 80 amp DC-GFP, connect the PV+ array output to the top of the PV disconnect breaker. The DC-GFP polarity will not be important. The polarity of the PV disconnect breaker is important!

The output of the PV charge controller also requires over-current protection. Most installations will use either a 63 amp din rail mount breaker or an 80 amp panel mount breaker. The + or "Line" side of this breaker must be connected to the Battery+ busbar. Use a red 6AWG wire for the 63 amp breaker and 4AWG wire for an 80 amp breaker. The charge controller output breaker must be sized large enough for the expected output. You can always use a larger breaker and wire than the array output though. The breaker is there to protect the wire, not the controller, so you can use a 63 amp breaker even if the controller is not capable of outputting more than 30 amps.

Solar Controller hook up: The E-Panel is set up to accept numerous controllers. These controllers may be installed on either side of the enclosure using brackets like shown below.

The bracket below is the standard bracket that comes with every E-Panel. If your controller must mount to the opposite side, then order a MNCCB-Left. This bracket directly accepts the MidNite Classic controller, OutBack MX60, FM60 and FM80. Some PWM controllers such as the Xantrex

C40/C60 and the Morningstar Tristar 60 can also mount to this bracket by adding an additional mounting hole. The Xantrex MPPT controller does not require a bracket. It mounts to the two holes marked with arrows.

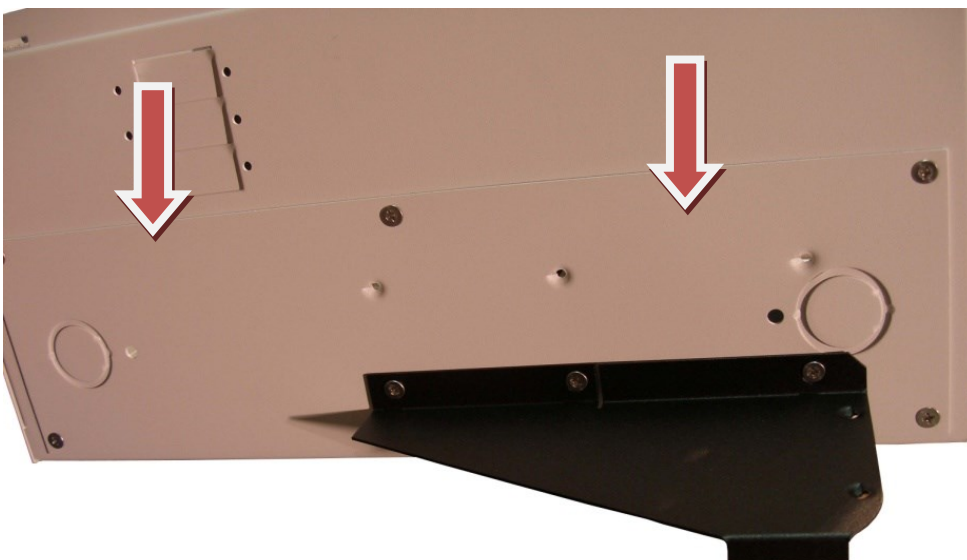

XW E-Panel installation manual



Wires pass through a 1" conduit knockout in the side plate. Install a 1" Close nipple, three 1" locknuts and two bushings to complete the wire passage. One of the locknuts is placed between the two enclosures to act as a spacer. The picture to the right shows the MidNite Classic installed. Note the two 80 amp panel mount breakers. The E-Panel can accept up to three panel mount breakers on either side and up to seven din rail mount breakers. Din rail breakers go up to 63 amps at the present. Panel mount breakers are available in 80 amps and even higher. Most controllers are too large to allow panel mount breakers to be mounted in front of the controller as is shown with the Classic here. Each charge controller must have a breaker/disconnect coming in from the PV combiner and also a breaker on the output of the controller. The need for breakers on both sides of the controller is an NEC requirement. Refer to the wiring diagram on page 6. A more complete wiring diagram is at the end of these instructions and on the inside of the door.

Inverter wiring compartment:

The E-Panel comes wired with 6AWG wire for all AC circuits. The left three terminals on the

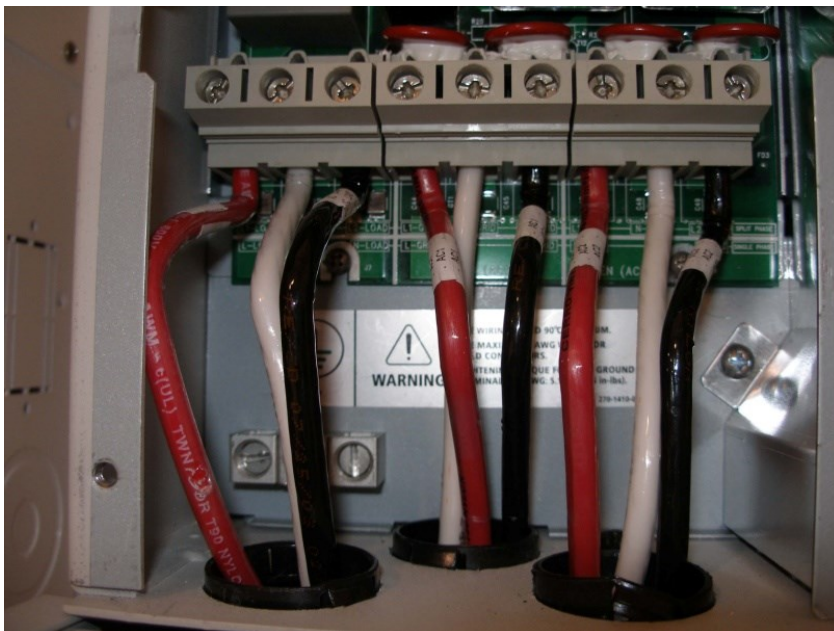

inverter are the AC output terminals. The output of the inverter terminals are wired to the E-Panel AC output terminal busbars. Wires are supplied and marked AC out. AC in 1 and AC in 2 are supplied and marked as such. These wires also connect to the E-Panel terminal busbars of the same name. Cut and strip these wires as required to hook up as shown. Refer to the inverter manual for torque values.

AC hook up: The E-Panel is supplied with 2 pole 60 amp

XW E-Panel installation manual

continuous breakers for the generator input, utility input and AC input/output bypass switch. Most generators come with a UL489 branch circuit output breaker. All main distribution/service entrance panels such as Square D utilize UL489 branch circuit rated breakers. The AC breakers supplied in the E-Panel are supplementary protection listed to UL1077. These breakers are used as disconnects or switches, but not as branch circuit devices. Branch circuit breakers made for a residential service entrance panels are typically thermal breakers. These breakers are not allowed under NEC guidelines to normally carry more than 80% of their rating. That means a 60 amp Square D QO stab in breaker may only be sized for 48 amps continuous power. The MidNite breakers are a hydraulic/magnetic variety and are allowed under NEC guidelines to carry full rated current. The XW E-Panel comes with 60 amp hydraulic/magnetic breakers.

Bus bars are provided for easy hook up from a generator and or the utility and also for an AC sub-panel. The AC input and output busbars are also the ideal place to connect lightning or surge arrestors. The output busbar must not be connected to the main distribution panel in a utility connected installation. The main utility connected distribution panel will go dead during an outage. Only circuits connected to the AC output busbar (sub-panel) will have power during a power outage. Do not try to back feed a utility connected distribution panel from the output of the inverter.

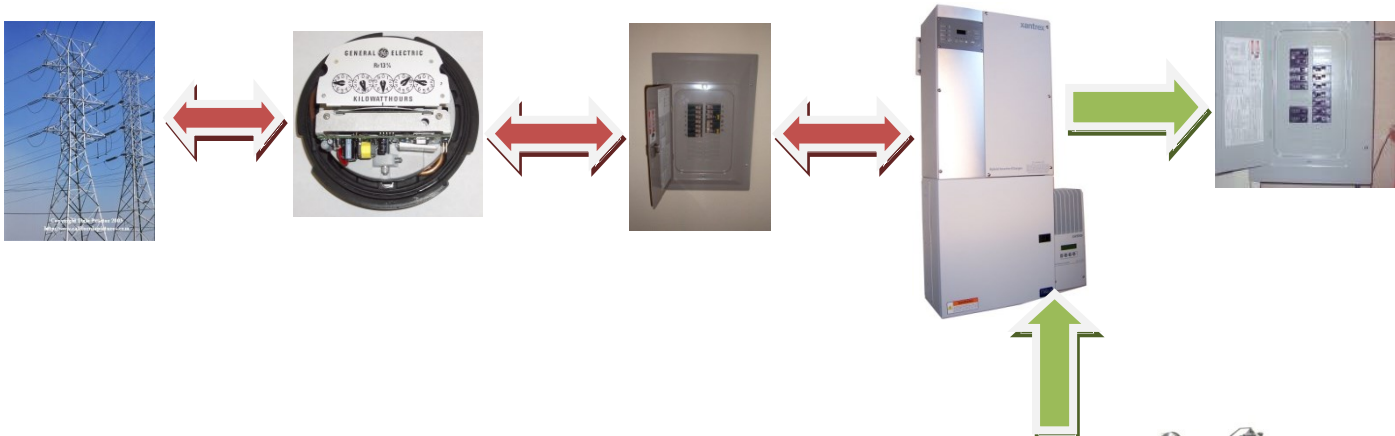

The above flow diagram shows AC current flow direction for a battery backed up grid tie system with a generator. DC current flow is not shown. Note that all loads powered by the inverter must be connected to the AC sub-panel on the right.



The above flow diagram shows AC current flow in an off-grid system. DC current flow is not shown.

This is a pictorial explanation of the main AC circuits. AC input1, AC input2 and AC output.

In a utility connected system, only the loads connected to the AC output Sub-panel will have power during an outage. The main service entrance loads will have no power.

XW E-Panel installation manual

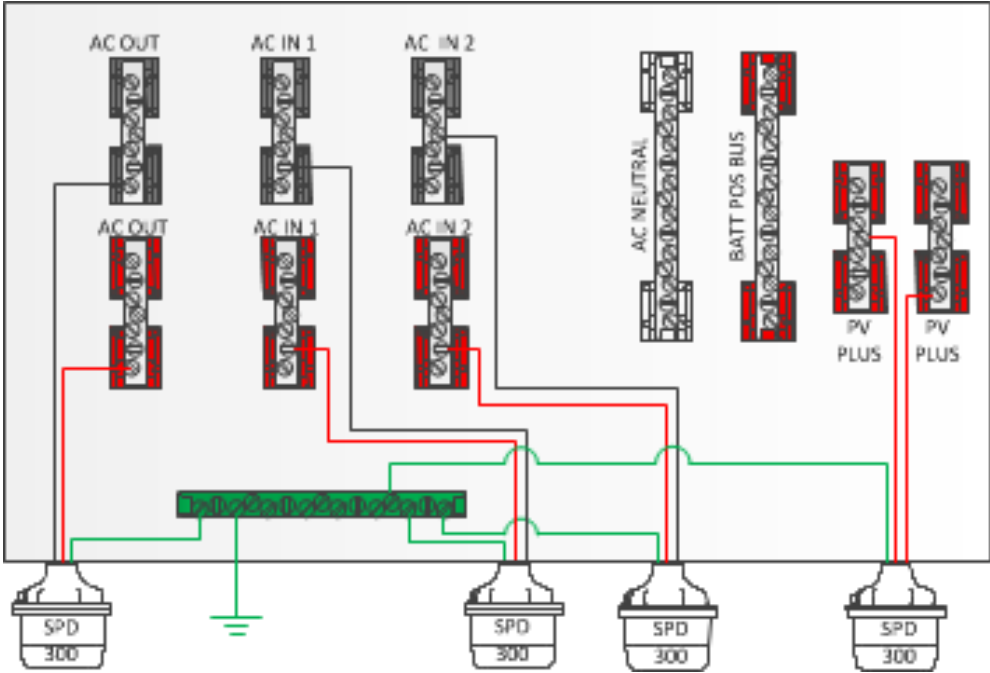
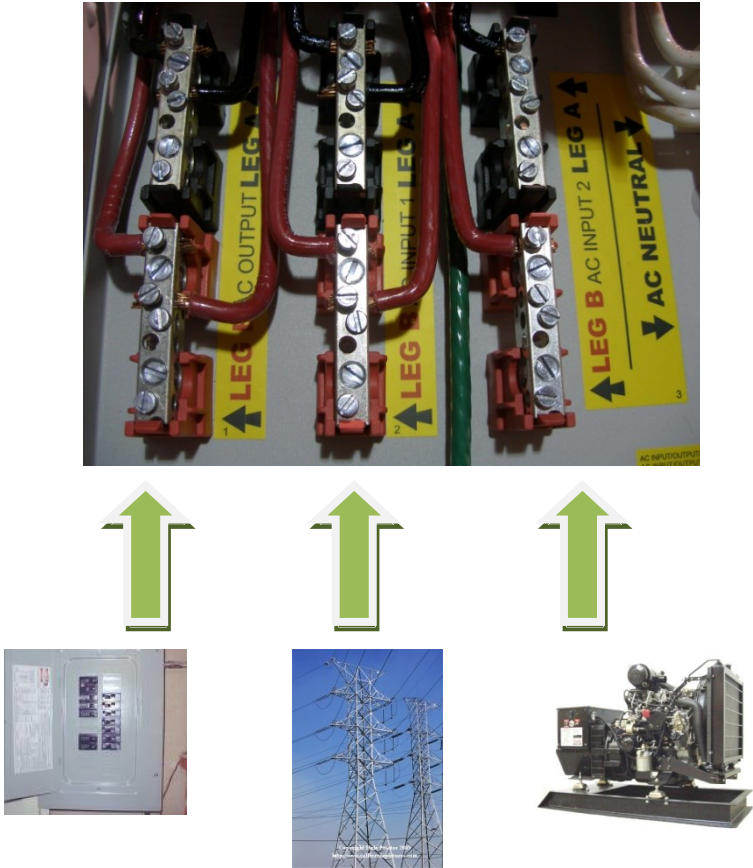

Lightning arrestor hook up. Note there is no arrestor on the battery bank. The Battery + lightning arrestor has marginal value since the batteries make a pretty large arrestor themselves. MidNite Solar does not endorse the Delta lightning arrestors shown. These are for reference only.

XW E-Panel installation manual

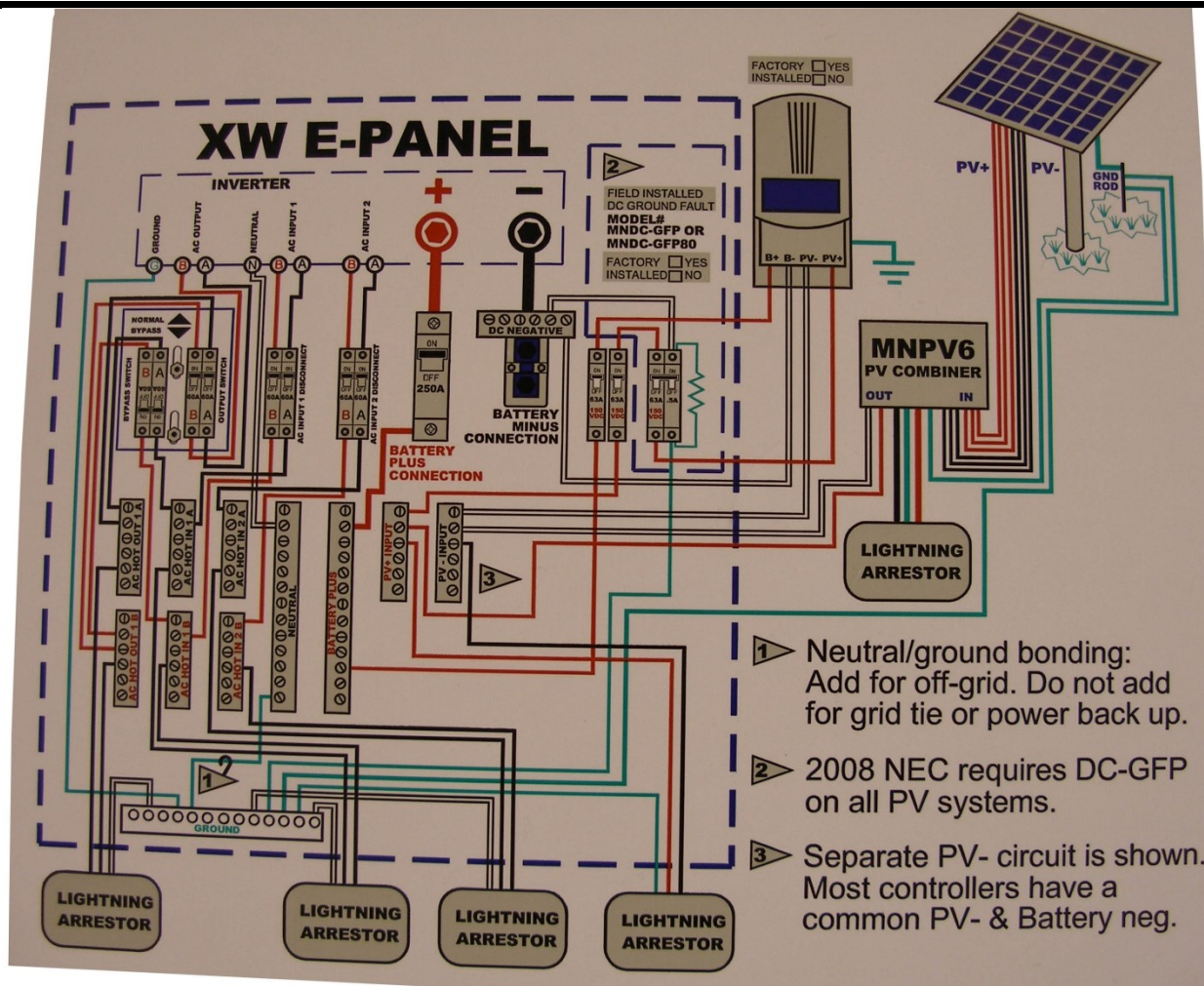

Door label, located on the inside of the door.

Other MidNite Solar components that may be included in the XW installation include:
 PV combiner MNPV3, MNPV6, MNPV12 or MNPV16

Battery enclosures MNBE-A, MNBE-B, MNBE-C, MNBE-D

DC din rail mount breakers: MNEPV1,2,3,4,5,6,7,8,9,10,12,15,20,30,40,50,63

DC panel mount breakers: MNEDC80

AC din rail mount single pole 120VAC breakers: MNEAC10,15,20 UL489 listed

AC din rail mount single pole 277VAC breakers: MNEAC30,40,50 or 60QZD

AC din rail mount 2 pole 20 amp 120/240VAC breakers: MNEAC20QZ2P

AC din rail mount 2 pole 30 amp 120/240VAC breakers: MNEAC30QZD2P

AC din rail mount 2 pole 50 amp 120/240VAC breakers: MNEAC50QZD2P

AC din rail mount 2 pole 60 amp 120/240VAC breakers: MNEAC60QZD2P

XW E-Panel installation manual

MNEXWSC

The MNEXWSC2 provides the AC interconnections and AC bypass for XW Inverters.

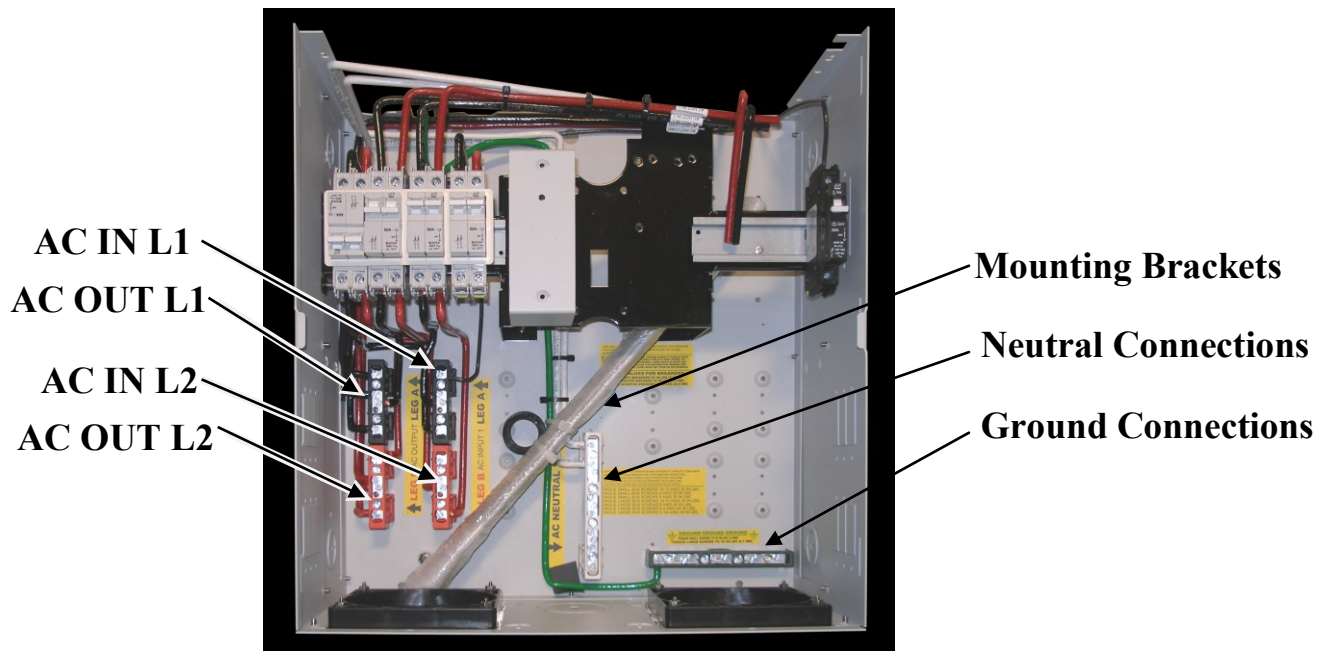
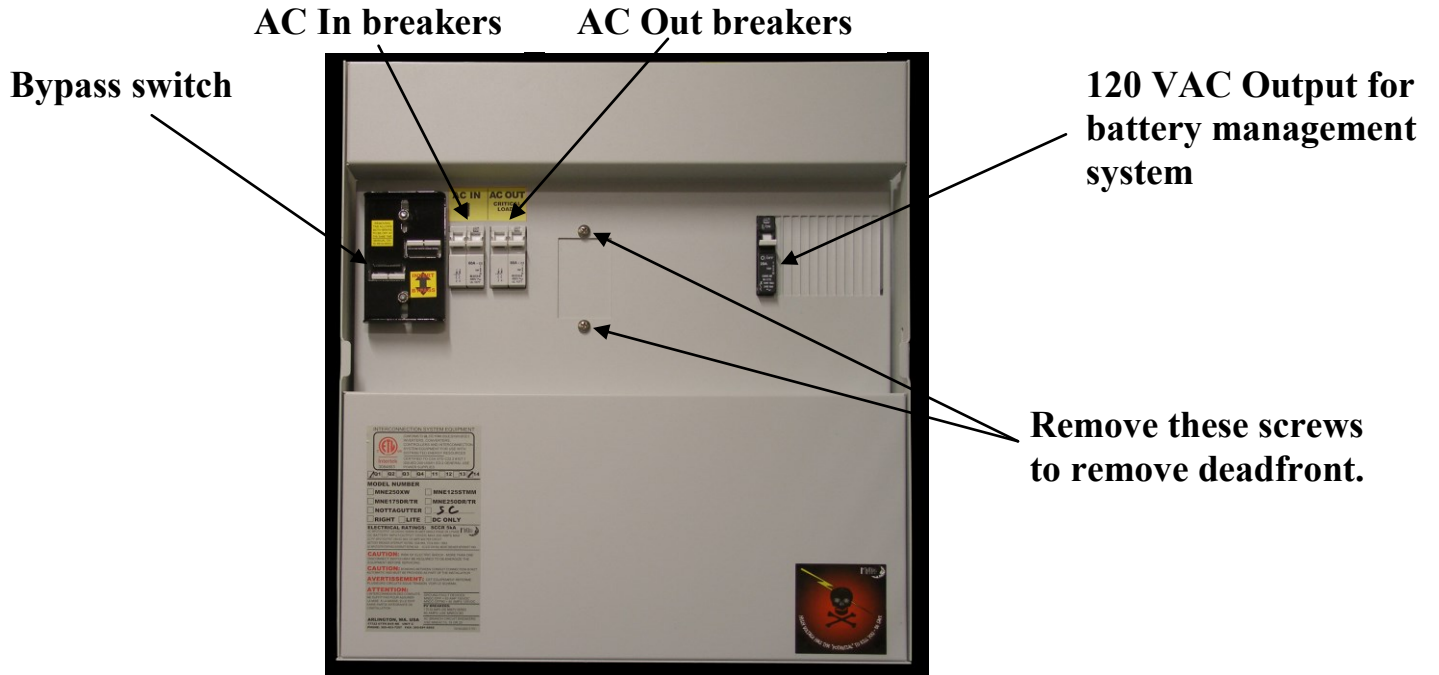

MNEXWSC Internal wiring

XW E-Panel installation manual

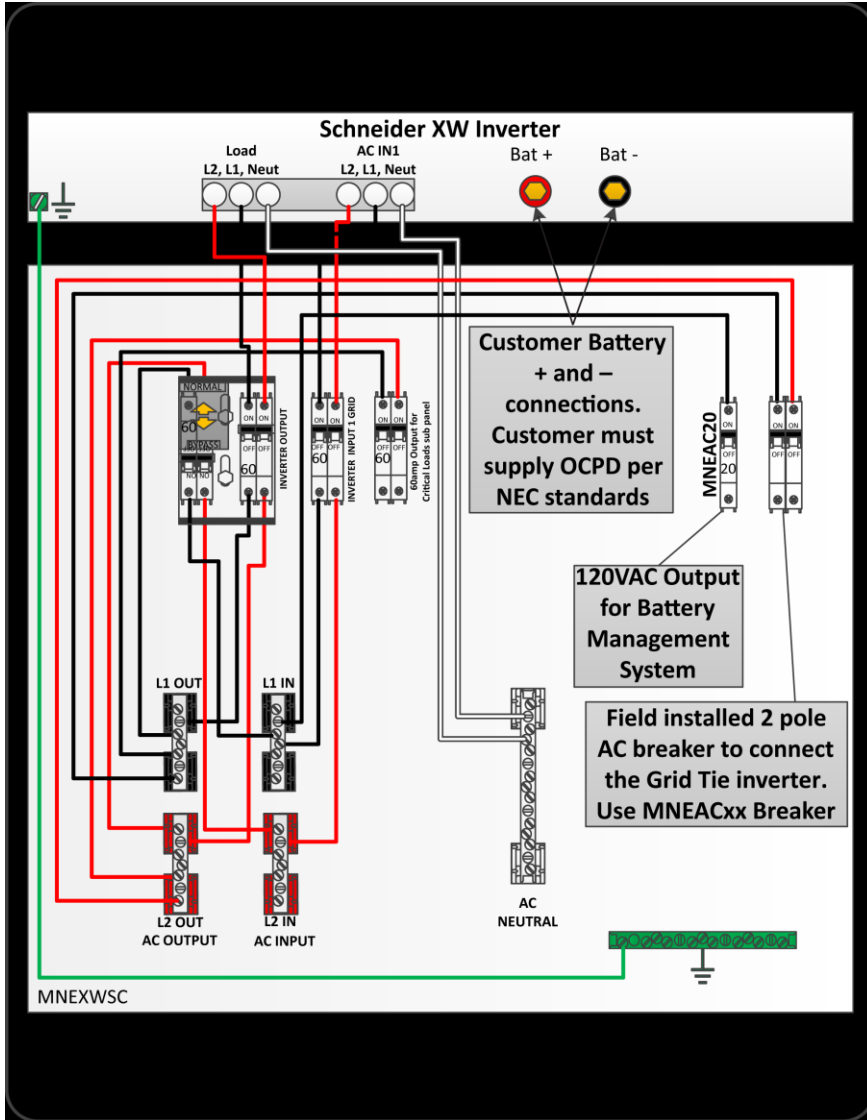

MNEXWSC Wiring Diagram

This diagram is also on the inside of the front cover of the E-Panel.

Stickers for the MNEXWSC E-Panel only.



XW Main Sticker set

AC INPUT	AC OUTPUT	NEUTRAL	GENERAL OUTLET	HYDRO OUTLET	WIND CONTROL INPUT	WIND CONTROL OUTPUT	AC CONTROL INPUT	AC CONTROL OUTPUT	BATTERY WINDER	BATTERY WINDER	GROUND PROTECT	DC TWO	PV INPUT ONE	PV INPUT TWO	PV ARRAY INPUT ONE	PV ARRAY INPUT TWO	PV ARRAY	LOAD CIRCUIT TWO	LOAD CIRCUIT THREE	LOAD CIRCUIT ONE	INVERTER BATTERY SHUTOFF	INVERTER	AC T	AC T
----------	-----------	---------	----------------	--------------	--------------------	---------------------	------------------	-------------------	----------------	----------------	----------------	--------	--------------	--------------	--------------------	--------------------	----------	------------------	--------------------	------------------	--------------------------	----------	------	------

PV + IN

BAT +

INVERTER BREAKER

AC INPUT/OUTPUT BREAKER MAX INTERRUPT CAPACITY: 5000 AMPS
AC INPUT/OUTPUT BREAKERS ARE SUPPLEMENTARY PROTECTION
EQUIPMENT. THEY DO NOT PROVIDE PROTECTION AGAINST
A DISTRIBUTION CENTER BUS AS THE ENCLOSURE FOR AC OUTPUT

TORQUE SMALL BUS SCREWS 14-10 AWG 20 IN. LBS.
TORQUE SMALL BUS SCREWS 8 AWG 25 IN. LBS.
TORQUE MEDIUM BUS SCREWS 10 AWG 35 IN. LBS.
TORQUE LARGE BUS SCREWS 8 AWG 40 IN. LBS.
TORQUE LARGE BUS SCREWS 4 AWG 45 IN. LBS.
TORQUE LARGE BUS SCREWS 3-10 AWG 50 IN. LBS.

USE ONLY WITH COPPER CONDUCTORS RATED 75°C MINIMUM
CONDUCTOR TEMPERATURE.
NOMINALE MANUALE DE 75. C.
BATTERY CABLES MUST BE FIVE STRAND SUPER FLEXIBLE SUCH
AS 1000 FT. 10 AWG 50 IN. LBS. OR 1000 FT. 10 AWG 50 IN. LBS.
CABLE SHOULD HAVE 1330 STRANDS. JAWES SHOULD HAVE ONE
STRAND PER 1000 FT. OF CABLE.
THE NATIONAL ELECTRIC CODE, SUCH AS THIN AN EXAMPLE

TORQUE VALUES FOR BREAKERS:
DIN RAIL MOUNT BREAKERS 20 IN. LBS. (2.2NM)
175 & 250A INVERTER BREAKER 20 IN. LBS. (2.2NM)
175 & 250A INVERTER BREAKER 220 IN. LBS. (24.9 NM)

GROUND GROUND GROUND
TORQUE SMALL SCREWS TO 20 IN. LBS (2.2NM)
TORQUE LARGE SCREWS TO 45 IN. LBS (5.1 NM)

AC IN 1

AC IN 2

LEG B AC OUTPUT LEG A

LEG B AC INPUT 1 LEG A

LEG B AC INPUT 2 LEG A

AC NEUTRAL

BATTERY PLUS BUS

BATTERY NEGATIVE

BATTERY POSITIVE

PV PLUS

PV MINUS

INTERCONNECTION SYSTEM EQUIPMENT

CONFORME TOUTES LES T141 ISSUE 2/19/12/ED 2
SERVICES, INVERTERS,
CONTROLLERS AND INTERCONNECTION
SYSTEM EQUIPMENT FOR USE WITH
DISTRIBUTED ENERGY RESOURCES

CERTIFIED TO CSA STD C22.2 #107.1
ISSUED 2001/09/01 ED 3 GENERAL USE
POWER SUPPLIES

Q1 Q2 Q3 Q4 14 15 16 17

MODEL NUMBER

MNE175XW MNE250XW

MNE125STMM MNEXWSC

NOTTAGUTTER

RIGHT LITE DC ONLY

ELECTRICAL RATINGS: SCCR 5KA
AC INPUT/OUTPUT 125VDC 1000A 1000A 1000A 1000A
DC BATTERY INPUT/OUTPUT 125VDC MAX 250 AMPS MAX
DC PV INPUT/OUTPUT 250VDC MAX 125 AMPS MAX PER CIRCUIT
BATTERY BREAKER INTERRUPT RATING 125A/5KA 175 & 250A + 50KA
AC INPUT/OUTPUT/DC INTERRUPT RATING 5KA 42.5C DIN RAIL BOUNT BREAKER INTERRUPT 10KA

CAUTION: RISK OF ELECTRIC SHOCK - MORE THAN ONE
DISCONNECT SWITCH MAY BE REQUIRED TO DE-ENERGIZE THE
EQUIPMENT BEFORE SERVICING

AVERTISSEMENT: CET EQUIPEMENT REQUIERE
PLUSIEURS CIRCUITS BOUT TENSION. VOIR LE SCHEMA

ATTENTION:
L'INTERCONNEXION DES CONDUITS
NECESSITE PLUSIEURS ASSUREUR
LA MISE A LA MASSE, ELLE DOIT
FAIRE PARTIE INTEGRANTE DE
L'INSTALLATION

GROUND FAULT DEVICES:
MIND-CGF P = ES AMF 150VDC
MIND-CGF P = 80 AMPS 125VDC
PV BREAKERS
1 TO 30 AMPS USE MNEP SERIES
80 AMPS USE MNE250C
AC BRANCH CIRCUIT BREAKERS
USE MNEAC15, 15 OR 20

ARLINGTON, WA, USA
17732 67TH AVE NE
PHONE: 360-463-7307 FAX: 360-691-6662

MIDNITE SOLAR INC. LIMITED WARRANTY **MidNite Solar Power electronics, sheet metal enclosures and accessories**

MidNite Solar Inc. warrants to the original customer that its products shall be free from defects in materials and workmanship. This warranty will be valid for a period of five (5) years for all products except the MNKID Charge Controller which will be two (2) years.

At its option, MidNite Solar will repair or replace at no charge any MidNite product that proves to be defective within such warranty period. This warranty shall not apply if the MidNite Solar product has been damaged by unreasonable use, accident, negligence, service or modification by anyone other than MidNite Solar, or by any other causes unrelated to materials and workmanship. The original consumer purchaser must retain original purchase receipt for proof of purchase as a condition precedent to warranty coverage. To receive in-warranty service, the defective product must be received no later than two (2) weeks after the end of the warranty period. The product must be accompanied by proof of purchase and Return Authorization (RA) number issued by MidNite Solar. For an RMA number contact MidNite Solar Inc., 17722 67th Ave NE, Arlington, WA 98223 (360) 403-7207.

Purchasers must prepay all delivery costs or shipping charges to return any defective MidNite Solar product under this warranty policy. Except for the warranty that the products are made in accordance with, the specifications therefore supplied or agreed to by customer:

MIDNITE SOLAR MAKES NO WARRANTY EXPRESSED OR IMPLIED, AND ANY IMPLIED WARRANTY OF MERCHANTABILITY OR FITNESS FOR A PARTICULAR PURPOSE WHICH EXCEEDS THE FOREGOING WARRANTY IS HEREBY DISCLAIMED BY MIDNITE SOLAR AND EXCLUDED FROM ANY AGREEMENT MADE BY ACCEPTANCE OF ANY ORDER PURSUANT TO THIS QUOTATION. MIDNITE SOLAR WILL NOT BE LIABLE FOR ANY CONSEQUENTIAL DAMAGES, LOSS OR EXPENSE ARISING IN CONNECTION WITH THE USE OF OR THE INABILITY TO USE ITS GOODS FOR ANY PURPOSE WHATSOEVER. MIDNITE SOLAR'S MAXIMUM LIABILITY SHALL NOT IN ANY CASE EXCEED THE CONTRACT PRICE FOR THE GOODS CLAIMED TO BE DEFECTIVE OR UNSUITABLE.

Products will be considered accepted by customer unless written notice to the contrary is given to MidNite Solar within ten (10) days of such delivery to customer. MIDNITE SOLAR is not responsible for loss or damage to products owned by customer and located on MIDNITE SOLAR'S premises caused by fire or other casualties beyond MIDNITE SOLAR'S control. This warranty is in lieu of all other warranties expressed or implied.

MIDNITE SOLAR INC. 17722 67TH AVE NE ARLINGTON, WA 98223

Email:

info@midnitesolar.com

PH: 360.403-7207 FAX: 360-691-6862